

CERN COURIER

International Journal of High Energy Physics



VOLUME 23



NOVEMBER 1983

Special W, Z

Laboratory correspondents:

Argonne National Laboratory, USA
W. R. Ditzler
Brookhaven National Laboratory, USA
N. V. Baggett
Cornell University, USA
D. G. Cassel
Daresbury Laboratory, UK
V. Suller
DESY Laboratory, Fed. Rep. of Germany
P. Waloschek
Fermi National Accelerator Laboratory, USA
R. A. Carrigan
KfK Karlsruhe, Fed. Rep. of Germany
M. Kuntze
GSI Darmstadt, Fed. Rep. of Germany
H. Prange
INFN, Italy
M. Gliarelli Fiumi
Institute of High Energy Physics,
Peking, China
Tu Tung-sheng
JINR Dubna, USSR
V. Sandukovsky
KEK National Laboratory, Japan
K. Kikuchi
Lawrence Berkeley Laboratory, USA
W. Carithers
Los Alamos National Laboratory, USA
O. B. van Dyck
Novosibirsk Institute, USSR
V. Balakin
Orsay Laboratory, France
Anne-Marie Lutz
Rutherford Appleton Laboratory, UK
D. Cragg
Saclay Laboratory, France
A. Zylberstejn
SIN Villigen, Switzerland
J. F. Crawford
Stanford Linear Accelerator Center, USA
L. Keller
TRIUMF Laboratory, Canada
M. K. Craddock

Copies are available on request from:

Federal Republic of Germany —
Gerda v. Schlenther
DESY, Notkestr. 85, 2000 Hamburg 52

Italy —
INFN, Casella Postale 56
00044 Frascati
Roma

United Kingdom —
Elizabeth Marsh
Rutherford Appleton Laboratory, Chilton,
Didcot
Oxfordshire OX11 0QX

USA/Canada —
Margaret Pearson
Fermilab, P. O. Box 500, Batavia
Illinois 60510

General distribution —
Monika Wilson
CERN, 1211 Geneva 23, Switzerland

CERN COURIER is published ten times yearly
in English and French editions. The views
expressed in the Journal are not necessarily
those of the CERN management.

Printed by: Presses Centrales S.A.
1002 Lausanne, Switzerland

Published by:

European Laboratory for Particle Physics
CERN, 1211 Geneva 23, Switzerland
Tel. (022) 83 61 11, Telex 23 698
(CERN COURIER only Tel. (022) 83 41 03)

USA: Controlled Circulation
Postage paid at Batavia, Illinois

Editors: Brian Southworth, Gordon Fraser, Henri-Luc Felder (French edition) /
Advertisements: Micheline Falciola / Advisory Panel: J. Prentki (Chairman),
J. Allaby, J. Cronin, K. Hübner, E. Lillestøl

VOLUME 23 N° 9

NOVEMBER 1983

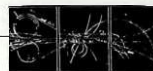

The discovery of 'heavy light'	355
<i>Putting the W and Z discoveries in perspective</i>	
Piecing together a theory	362
<i>The development of the 'electroweak' picture</i>	
From AA to Z	365
<i>The accelerator physics which made the new discoveries possible</i>	
The experiments	370
<i>Portrait of UA1 and UA2</i>	
Groundbreaking for LEP	377
<i>French and Swiss Presidents see work for new CERN machine get under way</i>	
Around the Laboratories	
FERMILAB: Going for antiprotons/Update on the Doubler-Saver . . .	380
<i>2 TeV matter-antimatter collisions the objective/Higher energies in superconducting ring</i>	
SERPUKHOV: RICH physics	384
<i>Ring Imaging Cherenkov counter</i>	
LOUVAIN-LA-NEUVE: Fourfold energy boost	385
<i>New cyclotron techniques in action</i>	
People and things	386

Cover photograph: Another chapter of CERN history begins. On 13 September, President François Mitterrand of France addressed the visitors and CERN staff assembled for the official groundbreaking ceremony of CERN's new LEP electron-positron ring. Seated on the platform, against a backdrop of flags of CERN Member States, is President Pierre Aubert of Switzerland. After the momentous discoveries at CERN of the W and Z particles which carry the weak nuclear force, LEP will enable this new physics to be explored in detail. This issue of the CERN COURIER is largely given over to the story behind these latest discoveries (Photo CERN X581.9.83).



The discovery of 'heavy light'

The discoveries of the W and Z bosons at CERN this year must rank among the greatest achievements in the history of science. They are the culmination of deep theoretical inspiration, technological excellence, dedicated experimentation, and teamwork on a scale never before seen in the realm of pure science. This special issue of the CERN COURIER commemorates these momentous exploits. The first article is a general story of the significance of the discoveries and how they came about. Then we trace in more detail the evolution of the new physics ideas which the W and Z discoveries have confirmed, the development at CERN of the techniques which made the experiments possible, and finally, the course of the two experiments themselves.

Also in this issue we cover the official groundbreaking ceremony marking the start of the civil engineering work for CERN's new LEP electron-positron ring, attended by President François Mitterrand of France and President Pierre Aubert of Switzerland. The discoveries of the W and Z particles provided the physics 'groundbreaking' for the new machine, which will be able to explore in depth the implications of this new physics.

*Brian Southworth
Gordon Fraser*

In May 1983, the central detector of the UA1 experiment at CERN reveals the tell-tale signature of the long-awaited Z particle as it decays into an electron-positron pair (arrowed).

For some thirty years the development of accelerators and storage rings have allowed particles to be collided together at higher and higher energies. The access to increasing energy, which can convert into matter in accordance with Einstein's famous equation, has revealed the existence of several hundreds of short-lived particles in addition to the tiny handful of stable particles, like the proton and electron, of which our Universe is built. If so many particles have already been found, why the jubilation about finding yet two more? Why should the discovery of the W and Z have generated so much excitement in the world of physics?

Discovering the role of light

The story goes back over a hundred years. A good starting point would be 1864 when the Scottish physicist James Clerk Maxwell published a paper called 'The Dynamical Theory of the Electromagnetic Field'. For some time it had been known that electrical and magnetic effects accompany one another — for example, a wire carrying a current is surrounded by a magnetic field, but it needed the genius of Maxwell to construct the equations which link electricity and magnetism. Two types of behaviour, previously con-

sidered apart, were brought together in one theory. It was a tremendous advance in understanding — phenomena as different as a high voltage spark, the pattern of iron filings scattered in a magnetic field, electrical currents, the swing of a compass needle, etc., etc. could all be explained from the same source.

Maxwell's famous equations also suggested something else; they very much resembled the equations describing waves, hinting that electromagnetic energy could be transmitted in this way. The existence of such electromagnetic waves was confirmed several years later in experiments by Heinrich Hertz.

The human eye is sensitive to electromagnetic radiation of a small band of wavelengths, ranging from those corresponding to red through to violet light. Thus light is just one aspect of electricity and magnetism. Electromagnetic waves play the role of communicator in electrical and magnetic effects and resolve one of the famous philosophical puzzles of action at a distance. How, for example, does a negatively charged electron know that the positively charged proton is sitting in the nucleus (and hence goes into orbit around it)? Answer: electromagnetic waves radiating from each particle establish a communication between the charged particles.

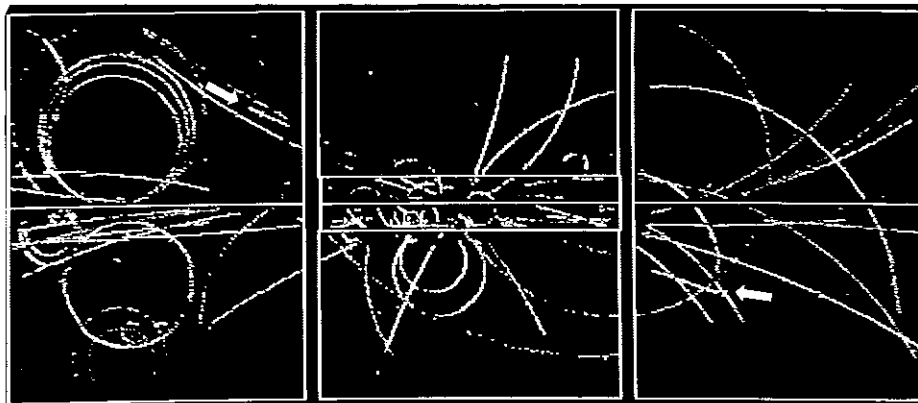

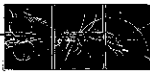

One hundred years before the formulation of the electroweak theory, James Clerk Maxwell started the ball rolling with his equations which provided a unified description of electricity and magnetism.

In the course of this century, the picture of electromagnetic waves has changed with the advent of quantum theory. At the atomic level the radiation is granular, emitted and absorbed in 'lumps' rather than smooth, continuous waves. These lumps of energy communicating electromagnetism are called photons, the particles of light. They have no mass and can communicate the electromagnetic force over great distances. The theory of 'quantum electrodynamics' is one of the most accurate known to science. Electromagnetic effects can be calculated with seemingly perfect precision.

Our W and Z story is a rerun of the electricity and magnetism story in which another range of phenomena is pulled into the theory and in which the Ws and Zs play the communicator role similar to that of light.

Understanding the weak nuclear force

At the turn of the century, J. Becquerel, Pierre and Marie Curie and others discovered radioactivity; photographic plates were fogged by some kind of radiation emerging from matter. Later investigations identified one type as 'beta decay', the emission of an electron from a neutron in the nucleus of the atom, converting it into a proton. Here at last the alchemists' dream of converting one chemical element to another was seen to be happening — but so feebly that its origin was named 'the weak nuclear force'. As well as its radioactivity, it plays a vital role in the burning of the sun, the formation of heavy elements, and many other phenomena.

The feebleness of the force, however, is not always the case. As energy (temperature) increases, the weak force gets stronger. In the ex-



treme temperatures of the great primaeval fireball which was the birth of the Universe, we now realize that electromagnetism and the weak force were one and the same thing. But as this fireball cooled down, it eventually reached a temperature where the weak interaction 'froze'. Beta radioactivity and other low energy weak force effects are only the fossil remains of what happened in this early Universe. However modern accelerators and storage rings, like LEP, can recreate those primaeval conditions and we can see again the 'weak' interaction rise to rival electromagnetism in strength.

The realization that the more obscure phenomena due to the weak force could be added to the same theory that covered the long list of 'everyday' electromagnetic effects was slow to come and its tortuous zig-zag progress is described on page 362.

The quest for unification — to explain as many things as possible from a minimal number of postulates — is a central theme in basic physics. After developing his momentous theories of relativity and gravitation earlier this century, Albert Einstein spent much of his life unsuccessfully trying to weld gravitation and electromagnetism. On a different front, Enrico Fermi and others in the 1930s looked at the possibility of unifying electromagnetism and weak force. Sheldon Glashow, getting nearer, tried again in the early 60s. But it needed the development of vital new concepts before Abdus Salam and Steven Weinberg, working independently in the mid 60s, came up with an innovative solution. These powerful intuitive ideas needed to be checked against experiment. Also, the theory could not yet be cast in a form capable of providing precise, unique predictions. But by 1971, the theoretical recipe had been completed, and it was up to experimenters to make the next steps.

The theory, now usually called the electroweak theory (a name adopted by Salam), predicted the existence of heavy particles to communicate the weak force. It also indicated that they would come in two types, now called W (which is the communicator when the particles involved exchange electrical charges) and Z (when no charge exchange takes place).

But when the theory took shape, this second type of weak interaction, where the particles involved do not swap charges, had never been observed. The first convincing clue that the theory was on the right track was the discovery of such 'weak neutral currents' in neutrino experiments, first at CERN and then at Fermilab, in 1973.

In the meantime, a nagging prob-

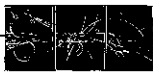

The discovery of 'weak neutral currents' at CERN in 1973 showed that the new electroweak theory was on the right track. In the photograph, a high energy neutrino has passed through the Gargamelle bubble chamber, itself undetected, but in its wake setting other particles in motion.

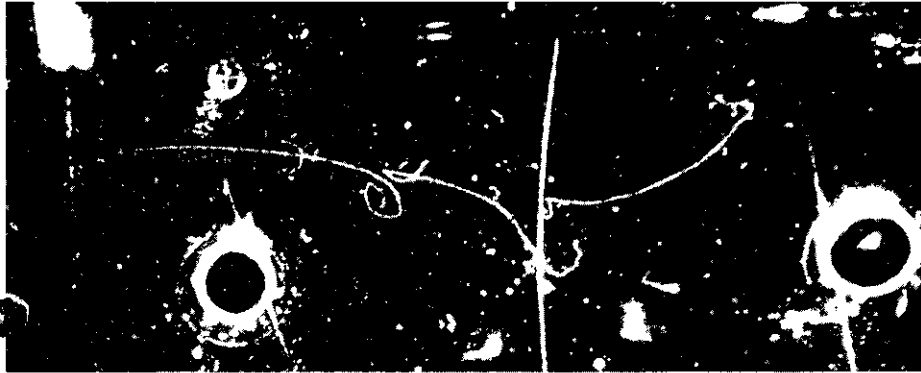

lem had been solved. In the first formulation of the theory, other neutral current interactions (in addition to those eventually seen in the neutrino experiments) could exist. An example is the decay of a neutral kaon into two muons. But such a decay had never been seen. Glashow, John Iliopoulos and Luciano Maiani predicted a new constituent of matter, the charmed quark, which prevented this type of kaon decay in a natural way.

This prediction was dramatically vindicated in 1974 in the experiments of Burt Richter at SLAC and Sam Ting at Brookhaven which found charmed particles.

Confidence was boosted further in 1978 when a remarkable experiment at the big linear electron accelerator at Stanford succeeded in measuring tiny asymmetries due to the delicate interference between electromagnetism and the weak neutral current. At

just one part in ten thousand, these were at the level predicted by the new theory. The stage was set for the final 'coup de théâtre' — the discovery of the W and Z particles, the predicted communicators of the weak force.

The electroweak theory, combined with results from new experiments, made precise predictions of the properties of these carrier particles. At some 80 and 90 times the mass of the proton respectively, the W and Z would be the heaviest particles ever seen — about as heavy as a nucleus of strontium. For the first time, physicists knew where they would have to look to find the long-sought carriers of the weak force.

However in the late 1970s such heavy particles were beyond the energy range of any existing machine. Our story now swings to the brilliant achievements in accelerator physics which provided enough energy to make W and Z particles.



The invention of 'beam cooling'

The biggest jump in available energies at accelerator Laboratories came with the mastery of storage rings which enabled particles to be collided head-on into one another, so that no 'knock-on' energy is lost. The ability to collide electron and positron beams was developed at Frascati in collaboration with Orsay, inspired by Bruno Touschek, and at

On 13 September, President François Mitterrand of France (left) and President Pierre Aubert of Switzerland, watched by CERN Director-General Herwig Schopper (right), took up trowels to ceremonially seal the foundation stone for CERN's new LEP machine (see page 377). At LEP, the strength of the 'weak' nuclear force is expected to increase to rival that of electromagnetism, thus recreating conditions which existed in the first few minutes of the early Universe.

(Photo CERN 174.9.83)

Simon van der Meer, architect of the 'beam cooling' techniques which opened the door to the CERN antiproton project.



Stanford in collaboration with Princeton, led by Burt Richter. The ability to collide two proton beams was developed with the Intersecting Storage Rings (ISR) at CERN built by the team led by Kjell Johnsen.

Colliding electron and positron beams has the advantage of requiring only one magnet ring in which the particles of opposite sign circulate in mutually opposite directions. It would seem an obvious parallel step to collide protons and antiprotons using a single ring but this runs into the difficulty of producing sufficiently intense beams of antiprotons. Without these intense beams, the number of collisions when the particle beams cross is too low for the physicists to see anything of interest. The invention of so-called 'cooling' techniques made intense antiproton beams feasible and opened the door to the W and Z.

The technique of cooling gets its

name from the relationship between temperature and particle energy. However beam cooling refers not to a process whereby all the particle energies in a beam are reduced (so that the beam is made cold) but to a process which reduces (or 'cools') the spread of particle energies around a desired value. The significance of such a cooling is that a storage ring will accept and retain only a small span of energies around its design value. If antiprotons with an initially wide span of energies can be cooled into the small span of the storage ring, intense antiproton beams become feasible.

In 1972 a report entitled 'Stochastic damping of betatron oscillations in the ISR' was published. Its author is a brilliant accelerator physicist, Simon van der Meer, who concluded his paper with the following note: 'This work was done in 1968. The idea seemed too far-fetched at the time to justify publication. However the fluctuations upon which the system is based were experimentally observed recently. Although it may still be unlikely that useful damping could be achieved in practice, it seems useful now to present at least some quantitative estimation of the effect.' In this modest way the idea which has been crucial to the CERN experiments was launched.

The word 'stochastic' means random, and stochastic cooling works by reducing the random motion of particles in the beam so that they become concentrated around the desired value. It does this by observing the 'centre of gravity' of a slice of the beam using pick-up electrodes at one point of the ring. Signals are then sent across the ring to apply an electric field to the same slice of the beam, when it has travelled around, so as to nudge the centre of gravity towards the desired position. Because of the random motion of the

particles, this nudge acts unfavourably on some particles but it does what is wanted to most of them, so that the process is convergent. However it has to be repeated millions of times, progressively cooling the beam.

First tests were carried out in the ISR in 1974 and the results, though not startling, were enough to show that the idea worked. (It is entertaining to note that one Carlo Rubbia, of whom much more later, was not at all keen on giving time to this machine physics since he was then busy with an experiment at the ISR!)

To test the cooling technique, a small storage ring was rapidly converted at CERN in 1976-77. The ring was renamed ICE — Initial Cooling Experiment — and the results that it achieved in 1977-78 for stochastic cooling of a beam in all three dimensions were extremely encouraging. Antiproton beams of sufficient intensity to do colliding beam physics in the CERN Super Proton Synchrotron looked to be just about achievable.

The proton-antiproton project

The physicist who picked up the antiproton baton in 1976 and has run with it, through to the discoveries of the W and Z, is Carlo Rubbia. It was his breadth of interest which enabled him to appreciate the physics potential, to understand the accelerator possibilities and to conceive an overall scenario, including a major detector. Hundreds of people have contributed to the successes but there is no doubt that, throughout the story, Rubbia has been a constant driving force. He pulled together a large team to put forward an experiment proposal which was code-named UA1, after 'Underground Area' since its location on the SPS required a large cavern to be excavated. This



Carlo Rubbia at his UA1 detector. He has been a constant driving force in the CERN antiproton project, from its inception through to the scientific discoveries.

(Photo CERN 76.8.83)

team grew to involve some 130 physicists from 13 research centres — Aachen, Anney LAPP, Birmingham, CERN, Helsinki, Queen Mary College London, Collège de France Paris, Riverside, Rome, Rutherford, Saclay, Vienna and Wisconsin. Organizing the work of such a large collaboration has been an exercise in sociology in itself. The proposal for a huge 'general purpose' detection system to look at 540 GeV proton-antiproton collisions was accepted at the 27th Meeting of the CERN Research Board on 29 June 1978.

With the results from ICE, the proton-antiproton project necessary to perform the experiment could be sketched out (see page 365). Its main new component was an Antiproton Accumulator (AA) — a storage ring where stochastic cooling would produce the intense antiproton beams. It took only two years from construction authorization of this intricate machine to the announcement of first operation by Roy Billinge (who led the construction team) at the International Accelerator Conference at CERN in July 1980. For the experiments over the past two years the AA has performed with unbelievable reliability. While the AA was being built, the Proton Synchrotron and the Super Proton Synchrotron also needed massive attention to prepare them for the new gymnastics with antiproton beams. The aim was to collide protons and antiprotons, with adequate beam intensities, in the Super Proton Synchrotron with an energy of 270 GeV per beam (an energy that the SPS could sustain with its magnets operating in a d.c. rather than pulsed mode).

The CERN management, and particularly the Research Director-General Leon Van Hove, showed considerable courage and determination in backing the project in mid-1978.



CERN has a heavy responsibility to provide appropriate research facilities for a community of some 3000 high energy physicists. There are understandable reasons, with so many physicists breathing down your neck, to back 'safe' experiments. The proton-antiproton project seemed in 1978 only just technologically feasible and there was no guarantee, even if all went well technically, that it would be possible to ex-

tract clean physics. Throwing three quarks and three antiquarks, plus their gluon companions, at one another at the high energy of 540 GeV, even at modest beam intensities, would produce a lot of confused debris. Also the project ate considerably into the money, time and manpower resources available for many other experiments. The Research Board's decision was therefore not an easy one and at the time it was

One of the first pictures of a 540 GeV proton-antiproton collision, as recorded in the big streamer chambers of the UA5 experiment at the CERN SPS.

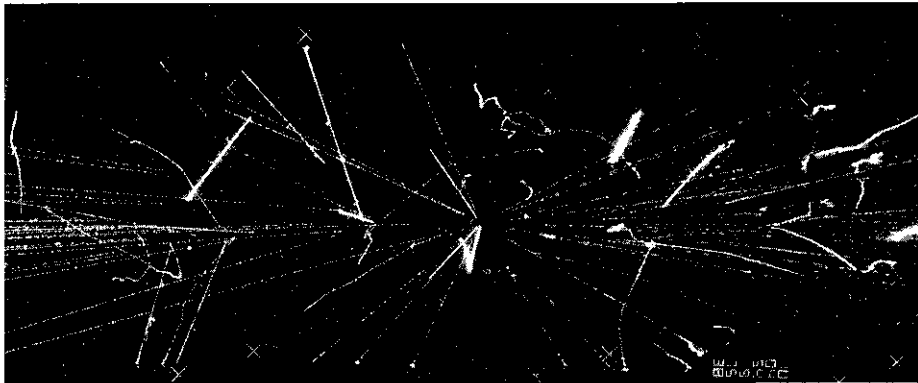

not universally acclaimed.

However, if the gods were kind, it was clear that dramatic physics was within CERN's grasp. A minor goad to CERN at that time was a series of media comments implying that the Laboratory, though furnishing a huge quantity of thorough physics, consistently missed the headline discoveries. This was not really fair since discoveries like the neutral currents rank with any, but it had enough truth to be an irritant. Our American colleagues had more often shown a flair and imagination in experiments that produced Nobel Prizes. The proton-antiproton project demanded flair and imagination and, happily, the courage was there to pick up the challenge.

In December 1978, the commitment went further. A second big experiment, UA2, was approved for another collision region on the SPS. This collaboration of some fifty physicists from Bern, CERN, Copenhagen, Orsay, Pavia and Saclay is led by Pierre Darriulat.

Finding the W and Z

In February 1981, the Proton Synchrotron received and accelerated antiprotons from the AA, thus becoming the world's first Antiproton Synchrotron. On 7 July transfer to the SPS, acceleration and brief

storage at 270 GeV were achieved. Carlo Rubbia delayed his departure to the Lisbon High Energy Physics Conference by a day so that on 10 July he was able to announce that the UA1 detector had seen its first proton-antiproton collisions. There were runs at modest intensities in the second half of the year and the first visual records of the collisions came from another experiment (UA5) using large streamer chambers. UA5 was then moved out to make way for UA2, which took its first data in December.

In 1982 an accident to UA1 forced a concentration of the scheduled proton-antiproton running into a single two-month period at the end of the year (October to December). In terms of operating efficiency, it proved a blessing in disguise and Research Director Erwin Gabathuler happily sacrificed a crate of champagne to the machine operating crews as the collision rate was taken to ten times that of the year before. This was the historic run in which the Ws were first observed.

It was astonishing how fast physics results were pulled from the data accumulated up to 6 December 1982. At a 'Topical Workshop on Proton-Antiproton Collider Physics' held in Rome from 12-14 January 1983, the first tentative evidence for

Pierre Darriulat, leader of the UA2 experiment.

observation of the W particle by the UA1 and UA2 collaborations was there. Out of the several thousand million collisions which had been seen, a tiny handful gave signals which could correspond to the production of a W in the high energy collision and its subsequent decay into an electron (or positron if the W was positively charged) and a neutrino. The detectors were programmed to look for high energy electrons coming out at a relatively large angle to the beam direction. Also energy imbalance of the particles around a decay indicated the emergence of a neutrino, which itself cannot be detected in the experimental apparatus.

The tension at CERN became electric, culminating in two brilliant seminars, from Carlo Rubbia (for UA1) on Thursday 20 January and Luigi Di Lella (for UA2) the following afternoon, both with the CERN auditorium



On 25 January 1983, CERN called a press conference to announce the discovery of the W particles.

(Photo CERN 244.1.83)



packed to the roof. UA1 announced six candidate W events; UA2 announced four. The presentations were still tentative and qualified. However over the weekend of 22-23 January, Rubbia became more and more convinced. As he put it, 'They look like Ws, they feel like Ws, they smell like Ws, they must be Ws'. And on 25 January a Press Conference was called to announce the discovery of the W. The UA2 team reserved judgement at this stage but further analysis convinced them also. What was even more impressive was that both teams could already give estimates of mass in excellent agreement with the predictions (about 80 GeV) of the electroweak theory.

It was always clear that the Z would take longer to find. The theory estimated its production rate to be some ten times lower than that of the Ws. It implied that the machine phy-

sicists had to push their collision rates still higher, and this they did in style in the second historic proton-antiproton run from April to July 1983. They exceeded by 50% the challenging goal that had been set and this time it was Director-General Herwig Schopper who forfeited a crate of champagne.

Again there was tension as the run began because the Z did not seem keen to show itself. Although more difficult to produce than the W, its signature is easier to spot because it can decay into an electron-positron pair or a muon pair. Two such high energy particles flying out in opposite directions were no problem for detectors and data handling systems that had so cleverly unearthed the W.

On 4 May, when analysing the collisions recorded in the UA1 detector a few days earlier, on 30 April, the characteristic signal of two opposite

high energy tracks was seen. Herwig Schopper reported the event at the Science for Peace meeting in San Remo on 5 May. However the event was not a clean example of a particle-antiparticle pair and it was only after three more events had turned up in the course of the month that CERN 'went public', announcing the discovery of the Z to the Press on 1 June. Again the mass (near 90 GeV) looked bang in line with theory. Just after the run, Pierre Darriulat was able to announce in July that UA2 had also seen at least four good Z decays.

In addition to the Ws and Zs, the observed behaviour was everything the electroweak theory predicted. Two independent experiments had confirmed a theory of breathtaking imagination and insight. This is one of the great milestones in man's quest to understand the Universe around him.

Piecing together a theory

In 1968, Abdus Salam spoke of the 'dream' of unifying weak and electromagnetic interactions in a single theory. Fifteen years later, his dream was found to be a reality.

A new physical theory needs many ingredients. In addition to the basic physics insights, it requires new techniques and formalism. The development of these ingredients cannot be guaranteed to happen in the optimal order, and experts working in one field may not even know that useful progress is being made somewhere else. Fettered by preconceptions and blinded by ignorance, even the most gifted scientists sometimes have to blunder their way through the unknown.

The development of what is now called the 'electroweak' picture illustrates how a complex theory, elegant and supremely logical when viewed with hindsight, is pieced together with almost exasperating slowness.

Gauge theories

The formulation of the laws of physics in terms of 'gauge' theories must be one of the major intellectual achievements of this century.

The oldest gauge theory is that of electromagnetism. Every physics student is familiar with the potentials from which electric and magnetic fields can be calculated. But potentials are not directly observable. Maxwell's equations fix only potential differences, and potentials can be suitably modified without upsetting the physics. These modifications are called 'gauge transformations', and Maxwell's equations are said to be 'gauge invariant'.

As sometimes happens in physics, the word 'gauge' stems from a misconception. Hermann Weyl once suggested the changes in electromagnetic potentials should correspond to some change in a basic length parameter, or gauge. This was soon recognized to be incorrect, but the name stuck.



Gauge transformations are characterized by arbitrary functions, as opposed to transformations which depend on a finite number of parameters. Thus ordinary rotations, which are completely described by three angles, do not permit gauge transformations.

The method for handling gauge theories was developed in the mid 50s by C.N. Yang and R. Mills, and independently by R. Shaw. But application of these techniques required first the injection of imaginative new physics ideas.

The dream of unification

Addressing a Nobel Symposium at Lerum in Sweden in 1968, Abdus Salam spoke of the 'dream' of unifying weak and electromagnetic interactions in a single theory. Apart from the aesthetic appeal of having one

picture instead of two, there were clues which pointed towards such a unification.

But Salam was not the first to have this dream. Enrico Fermi had toyed with the idea back in 1934. By 1961, bold theoreticians, notably Sheldon Glashow, were putting forward detailed models. While these ideas contained more than a germ of truth, they were premature. The vital mechanism of spontaneous symmetry breaking was not yet understood.

As Glashow said in his 1979 Nobel lecture — 'the intermediate boson of neutral currents had to be made very much heavier than its charged current counterparts. This was an arbitrary but permissible act in those days: the symmetry breaking mechanism was unknown. I had "solved" the problem of strangeness-changing neutral currents by suppressing all neutral currents: the baby was lost with the bath water.'

In the 1960s, Sheldon Glashow's bold ideas were vital to the development of the final form of the electroweak theory, applying to all particles.



At about this time, attention in particle theory was turning to the idea of 'spontaneous' symmetry breaking, already known in solid-state physics. A theory could possess an exact symmetry, but the physical states, particularly the vacuum, would not.

(An example of spontaneous symmetry breaking is a round dining table set for a meal. When the guests sit down, there is total symmetry, with a serviette between each person. In principle, each guest could take a serviette from his left or his right. However this symmetry is broken when the first guest picks up his serviette, conventionally from the left, and all the others have to follow suit.)

Initially, these ideas were unfruitful, as they produced an embarrassing proliferation of unwanted massless 'Goldstone bosons'. Describing his initial encounters with these the-

ories, Steven Weinberg said, 'I remember being so discouraged by these zero masses that I wrote a note to underscore the futility of supposing that anything could be explained in terms of a noninvariant vacuum'.

For the weak interactions, the field particles had to be heavy, and at first these masses could not be obtained without destroying the symmetry. The problem was only solved with the development of the so-called 'Higgs mechanism', which showed that the carriers of the weak force could be heavy, as long as they were accompanied by other ('Higgs') particles.

Once freed of unwanted massless particles, the next step was for Weinberg and Salam, working independently, to show how these new symmetry breaking ideas could be exploited in an elegant model which linked the carriers of the weak force with the photon, thus unifying elec-

tromagnetic and weak interactions.

But even this took time. In the mid 60s, particle theory was dominated by the 'eightfold way' — the approximate SU(3) symmetry incorporating isospin and strangeness.

Later, Weinberg described how he stumbled on the right idea. 'At some point in the fall of 1967, it occurred to me that I had been applying the right ideas to the wrong problem. It is not the rho meson that is massless: it is the photon. And its partner is not the A1, but the massive intermediate bosons, which since the time of Yukawa had been suspected to be the mediators of the weak interactions. The weak and electromagnetic interactions could then be described in a unified way in terms of an exact but spontaneously broken gauge symmetry.'

'Initially we were confused,' Salam admits. 'We were trying to gauge the wrong symmetry.'

Elegant and appealing though it was, the Weinberg-Salam model fell on unfertile ground. It described only leptons (electrons, muons and neutrinos) and said nothing about the weak and electromagnetic behaviour of the strongly interacting particles, hadrons.

The model predicted that there would be neutral currents, but none had ever been seen. If neutral currents existed, they should show up in particle decays. For instance the neutral kaon (carrying strangeness) should decay into two muons. Why were such strangeness-changing neutral currents suppressed?

Charmed

In 1964, Glashow (with Bjorken) tested the idea of extending the usual trio of quarks (up, down, strange) to four, with the introduction of the charmed quark. Part of the motiva-

Steven Weinberg — 'in 1967 it occurred to me that I had been applying the right ideas to the wrong problem'. This was quickly rectified, and physics made one great stride forward.

tion came from 'mistaken notions of hadron spectroscopy', but they were also eager to find a parallel between lepton and hadron behaviour under the weak interaction.

Says Glashow: 'Had we inserted these currents into the earlier theory (1961), we would have solved the problem of strangeness-changing neutral currents. We did not. I had apparently quite forgotten my earlier ideas of electroweak synthesis. The problem which was explicitly posed in 1961 was solved, in principle, in 1964. No one, least of all me, knew it. Perhaps we were all befuddled by the chimera of relativistic SU(6), which arose at about this time to cloud the minds of theorists.'

In 1969, Glashow, now working with John Iliopoulos and Luciano Maiani (the 'GIM' model) returned to the implications of the charmed quark and found that strangeness-changing neutral currents were naturally suppressed. 'It seems incredible that the problem was totally ignored for so long,' says Glashow.

Most of the physics ideas were now in place. The Weinberg-Salam model had unified weak interactions and electromagnetism. The GIM four-quark model showed how to construct the weak and electromagnetic currents of hadrons. But there was still a potential spanner in the works. The formalism was not 'renormalizable' — there was no set of well-defined rules (as in quantum electrodynamics) which naturally avoided calculations encountering infinities.

The renormalizability of gauge theories had been examined for some time, but it was Gerard 't Hooft in 1971 who proved that in this case it



In 1976 Burt Richter (left) and Sam Ting received the Nobel Prize for Physics in recognition of their discovery of new particles carrying 'charm'. The existence of this new type of matter was another important confirmation of the new theory.

From AA to Z

was possible. In theorist Sidney Coleman's words, 't Hooft's work turned the Weinberg-Salam frog into an enchanted prince.'

In 1979, Sheldon Glashow, Abdus Salam and Steven Weinberg shared the Nobel Prize for Physics, a courageous move by Stockholm in view of the fact that the W and Z particles predicted by the electroweak theory had not yet been discovered. As one notable experimenter was heard to remark on learning the news, 'does this mean they'll have to give the prize back if we don't find the Z?' The question was to remain a hypothetical one.

(Most of the quotes used in this article come from the Nobel laureates' lectures. Extracts were published in the CERN Courier, November 1980, pages 350-7, and the full versions are to be found in Reviews of Modern Physics, July 1980 issue, vol. 52 No. 3).

The conditions for proton-antiproton physics were attained thanks to a remarkable sequence of developments in accelerator physics.

The first ideas about beam cooling (though not, in the end, the ideas used in the CERN project) came in 1966 from the imaginative Gersh Budker and his colleagues at Novosibirsk. They were then launching a 25 GeV proton-antiproton storage ring named VAPP-NAP and obviously needed some scheme to produce intense antiproton beams.

They termed their technique 'electron cooling'. The idea was to run an electron beam along with the antiproton beam at the same velocity and to continually refresh the electron beam. The electrons have precisely the desired momentum and, in their collisions with the antiprotons, energy is transferred in such a way that the continually refreshed electron beam conditions gradually pre-

dominate. The antiproton beam settles around the desired momentum.

In 1974, tests led by A. N. Skrinsky in a small storage ring, NAP-M, at Novosibirsk demonstrated that cooling was being achieved. These results were confirmed later at CERN and at Fermilab. However the alternative idea of stochastic cooling (described in our opening article) from Simon van der Meer proved so successful that in the final schemes for proton-antiproton colliding beams at both CERN and Fermilab, electron cooling was dropped.

The first successful tests on stochastic cooling took place on 21 October 1974 on proton beams in the Intersecting Storage Rings. This followed the development of electronics sufficiently fast (GHz range) to allow the beam to be monitored in an intersection region on the machine (using two directional loop pick-ups connected to a differ-

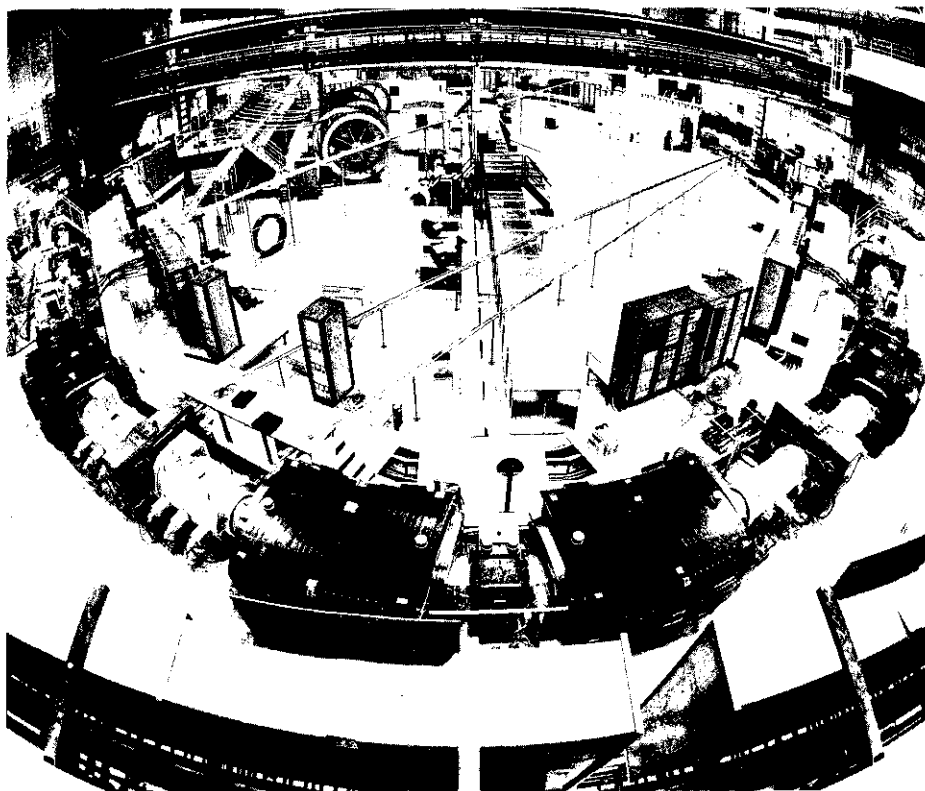

The Antiproton Accumulator, the heart of the CERN antiproton project.

(Photo 582. 10.80)

encing transformer) and to transmit the appropriately amplified signal to kicker magnets in the next intersection region. Thus the signal bypassed an arc of one eighth of the machine, racing the beam around the ring so that the same slice of beam could be acted upon. Over seven hours, a cooling rate of 2 per cent per hour was achieved.

This modest success gave encouragement to those who were working on the better understanding of the theory and on improving the hardware — people like Hugh Hereward, Dieter Möhl, Bob Palmer, Frank Sacherer, Peter Bramham, George Carron, Leo Faltin, Kurt Hübner, Wolfgang Schnell and Lars Thorndahl. The initial tests were concerned only with reducing the vertical spread of the beam. In 1976 the horizontal spread received the same treatment in the ISR and the results were again in excellent agreement with theory. With low intensity beams (around 5 mA), cooling rates went as high as 10 per cent per hour.

It was about this time that serious high energy proton-antiproton schemes began to emerge at CERN (spearheaded by Carlo Rubbia and studied in groups led by Franco Bonaudi) and at Fermilab (promoted by Dave Cline, Peter McIntyre, Fred Mills and Carlo Rubbia). At CERN, so as to gain more information on the potential of the two cooling techniques, it was decided rapidly to convert an existing small storage ring (the g-2 ring previously used for high precision measurements of the muon magnetic moment). The project became known as ICE, for Initial Cooling Experiment. The cooling physics was under the supervision of van der Meer, Guido Petrucci led the ring conversion, Thorndahl (who had developed a filter method for improving the effect of the cooling electronics) had responsibility for the

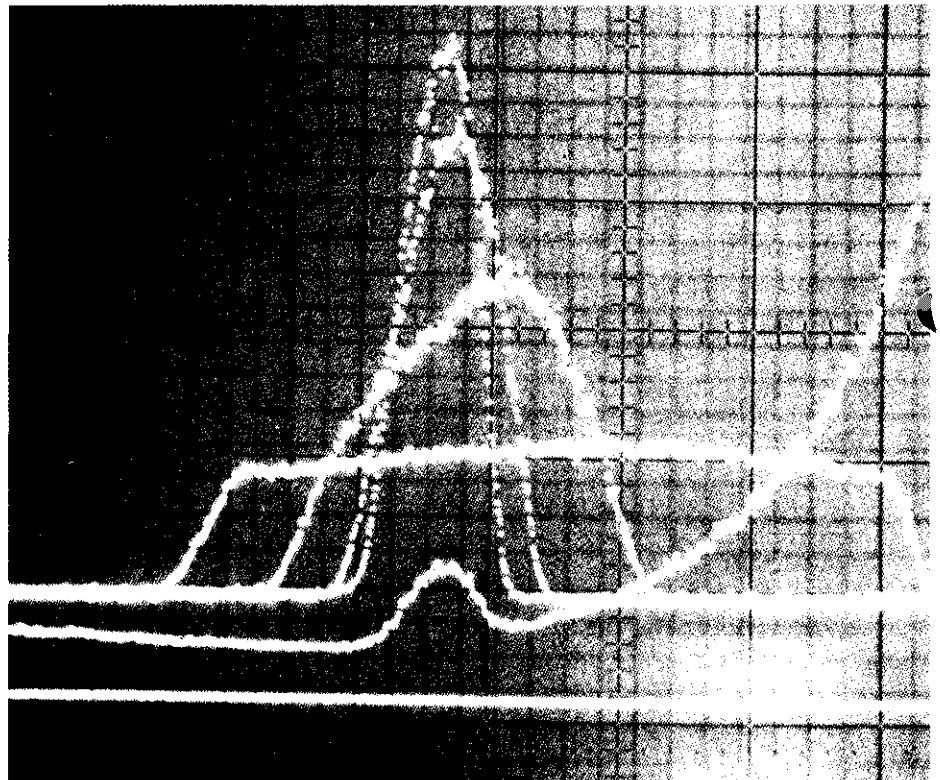

Experiments at the ICE ring at CERN in 1978 showed the shape of things to come. The lower trace with a broad flat plateau shows the wide spread of initial momenta in a stored proton beam. Stochastic cooling reduced the momentum spread, producing the successively sharper peaks.

stochastic cooling system and Frank Krienen for the electron cooling system.

The conversion was completed in nine months and on 5 December 1977 the ICE ring received its first protons. By Christmas stochastic cooling had been achieved in two dimensions. The emphasis by then, in terms of preferred technique, was swinging steadily towards stochastic cooling. This was because, back at the ISR, further work (reported by Oswald Groebner at the Serpukhov Accelerator Conference in July) had pushed cooling rates as high as 89 per cent per hour. The results from ICE carried the preference still further. By the end of March 1978, cooling rates had reached a factor of nine in three minutes.

In May cooling in three dimensions was achieved, demonstrating that compression in one dimension would not lead to blow up in another.

Cooling times were down to 15 s and momentum density increases were a factor of 20. The conviction that stochastic cooling could do the trick became more solid; the CERN proton-antiproton project was drawn up in detail and presented to the CERN Council for approval in June 1978.

(To conclude our story of the ICE age, in May 1979 electron cooling was tested for the first time. Good results were achieved during the year. There was also a nice bit of particle physics en route. Prior to ICE, the antiproton was known to be stable for at least 140 μ s. Every theoretician knows an antiproton lives as long as a proton, some 10^{30} years or more... but every experimenter doesn't believe all the theoreticians tell him. It was a comfort for the future of the antiproton project to observe an antiproton lifetime of at least many hours in ICE.)

The intricate layout of the CERN antiproton scheme.

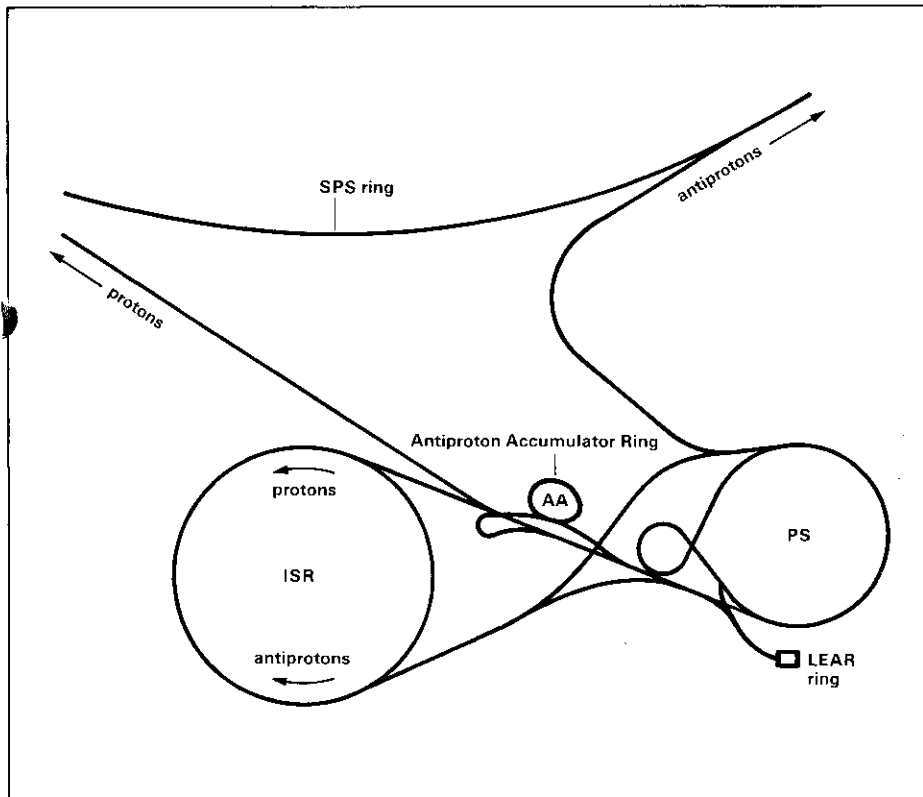

How the proton-antiproton project works

The heart of the project is the Antiproton Accumulator (AA), where beam cooling is applied to build up antiproton beams containing up to 6×10^{11} particles, tens of thousands of times more than have ever been achieved before.

Protons are first accelerated in the Proton Synchrotron (PS). Instead of being evenly distributed in twenty bunches around the PS ring, as in a 'normal' acceleration cycle, they are crowded in five bunches in a quarter of the ring. This reduced 'length' of proton beam produces a length of antiproton beam, when striking a target, which fills the circumference of the AA, which is one quarter that of the PS.

The sequence in the PS is to take 150 mA of protons at 50 MeV and

150 μ s pulse length from the linac into the 800 MeV four-ring Booster. The protons are ejected two rings at a time so that bunches are combined vertically. The resulting ten bunches are combined via the r.f. in the PS to give the required five bunches.

When the protons in the PS have reached an energy of 26 GeV they are ejected towards the AA and strike a target in front of the ring. From the spray of secondary particles which emerge, a focusing system (magnetic horn) selects antiprotons of energy around 3.5 GeV for injection into the AA. It is at this energy that the maximum yield of antiprotons from the target occurs. For each pulse of ten million million (10^{13}) protons on the target, it was anticipated that some 20 million (2×10^7) antiprotons would be injected into the ring; i.e., for every million protons hitting the target, only two antiprotons are collected. (This de-

sign prediction proved to be a factor of two too high and antiproton production has been a limitation on the performance so far.) These pulses are repeated every 2.4 seconds.

Since the AA is required to provide beams containing 6×10^{11} particles, some 100 000 pulses from the PS (about three days' operation of the machine) are needed to supply all these antiprotons.

The sequence of diagrams (next page) summarizes the stacking and cooling procedure in the AA. The black outer line indicates a cross-section through the vacuum chamber of the ring. The chamber is unusually large (70 cm wide) to give space for all the necessary manoeuvres, and it is held at a high vacuum (10^{-10} torr) to minimize loss of antiprotons due to collisions with residual gas molecules.

The first pulse is injected into the ring by 'kicker magnets' so that the antiprotons orbit on the outside of the vacuum chamber. During injection this outer region is shielded from the rest of the chamber by a mechanically operated metal shutter. This shields the antiprotons, which will be stacked in the main body of the chamber, from the magnetic fields of the kickers, and makes it possible to cool the low-density injected beam without being swamped by the much stronger signals from the high-density stack. The first injected pulse of some five million antiprotons is observed at pick-up stations, and other kicker magnets act upon it to cool the antiprotons.

In two seconds the injected pulse is precooled so that the random motion of the particles is reduced by a factor of ten. The shutter is then lowered and radiofrequency fields are applied to move the precooled antiprotons into the main body of the chamber (into the stack position).

The shutter rises again and the

The technique used in the Antiproton Accumulator to build up intense stacks of antiprotons.

second pulse is injected to receive the same treatment.

While the sequence of injection, precooling, and transfer to the stack proceeds, cooling systems act on the stack. Their aim is to further concentrate the beam, ultimately by a factor of a hundred million. (Compare this to the figures cited earlier from the initial tests!) After 150 pulses are stacked, some six minutes after injection began, about a thousand million (10^9) antiprotons are in the stack being progressively cooled.

After about 3 hours and four thousand five hundred injected pulses, when some 3×10^{10} antiprotons are orbiting in the stack, a distinct concentration at the value for which the cooling is tuned begins to appear. Within the stack a core is forming near the inside of the vacuum chamber.

After 120 hours and 180 thousand injected pulses, some million million (10^{12}) antiprotons are orbiting in the stack. The majority of them (6×10^{11}), after the many hours of cooling, are concentrated in the core, and radiofrequency fields are then applied to extract the core, providing the intense antiproton beam for colliding beam physics.

A residue of some 4×10^{11} antiprotons remains in the stack in the AA and this is used to start the formation of the next core. Injection of pulses of antiprotons continues so that after a time (about a day) another core of antiprotons is cooled and is ready for ejection.

Because of space limitations in the AA ring, the injection and ejection systems are located in the same section of the ring. It is therefore necessary to turn the antiproton beam around in a loop of magnets so that it travels towards the PS, where it is injected to circulate in the opposite direction to that of the protons. In the PS the antiprotons are accelerated,



The first pulse is injected into the vacuum chamber.



Precooling is applied.



The pulse is moved into the stack position.



The second pulse is injected 2.2 seconds later.



The second pulse is stacked after being pre-cooled.



150 pulses later, the stack intensity is 10^9 antiprotons.



After 3 hours, a dense core is forming in the stack.

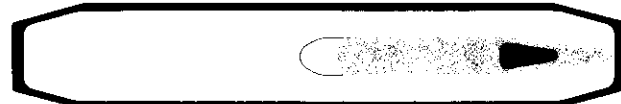

After 120 hours the core contains enough antiprotons to be ejected.



The remaining antiprotons are used to start the next core.

Roy Billinge and Co. in the control room of the Antiproton Accumulator during first successful tests in 1980.

(Photo CERN 77.7.80)



in several cycles a bunch at a time, from 3.5 to 26 GeV. At this energy they are sent to the SPS through a newly built transfer tunnel.

At the Super Proton Synchrotron the antiprotons and protons circulate in opposite directions in the same ring. Different injection schemes allow a choice of number of orbiting bunches in each beam. The two sets of bunches are accelerated simultaneously to 270 GeV using two separate radio frequency accelerating systems (an additional system was added to cope with the antiprotons). Using 'low beta insertions', special focusing magnets to squeeze the beams to small dimensions where they collide, the design luminosity (dictating the number of collisions which can be observed) is 10^{30} per square centimetre per second.

Since we are concentrating on the W and Z discoveries, this description of the machine scheme omits

the involvement of the Intersecting Storage Rings, which can also receive antiprotons in one of its rings, and of LEAR, the newly built Low Energy Antiproton Ring which receives decelerated antiprotons from the PS. (What a range of beam gymnastics the PS now has to perform; not bad for a machine which first came into operation 24 years ago!)

Performances to date

On 3 July 1980 proton beams were injected and stored in the Antiproton Accumulator for the first time, just two years after project authorization. Within days, magnet polarities were reversed and antiprotons were injected and cooled. Just a little earlier, on 16 June, the SPS began an eleven month shutdown for final modifications.

On 7 July 1981 the SPS acceler-

ated its first pulse of antiprotons to 270 GeV. Two days later, with a proton beam orbiting in the opposite direction, there was the first evidence of proton-antiproton collisions. In August the antiproton count reached 10^9 and the UA1 calorimeter recorded some 4000 events. In October the first visual evidence of the collisions was recorded in the streamer chambers of UA5.

The first extended run for physics took place in November and December when there were some 140 hours of operation with one bunch of antiprotons in collision with two bunches of protons. The peak initial luminosity was 5.2×10^{27} per cm^2 per s and the integrated luminosity was 2.3×10^{32} per cm^2 . This was too low to have a reasonable chance of seeing a W but it gave the experiment collaborations a good first taste of collider physics to keep them busy while operation was suspended until late 1982 to sort out the accident to the UA1 detector.

In October and November 1982 there were 748 hours, mainly with three antiproton bunches against three proton bunches, giving an integrated luminosity of 2.8×10^{34} with a peak initial luminosity of 5.1×10^{28} . Typical beam coasting time was 15 to 20 hours and one antiproton shot lasted for 42 hours. The threshold of machine performance had been crossed for observation of the W particles.

The collider run beginning on 12 April this year was even more spectacular. It began with more than a fair share of teething troubles but with consistently improving performance and reliability. When the run was interrupted for maintenance on 16 May, the AA had been ticking over for 808 hours without losing a single stack. After the halt, the low beta quadrupoles were on and the peak initial luminosity climbed to

The experiments

1.6×10^{29} . By the time the run closed on 3 July the integrated luminosity had reached 1.5×10^{35} . The threshold of machine performance had been crossed for observation of the Z particles.

Future plans

At the PS the present ten bunches from the booster will be 'box car' stacked in the transfer line so as to give five bunches in the PS. This process can then be repeated to feed in another five bunches and the process of combination in the PS ring will result in putting more protons (some 2×10^{13}) on the antiproton production target at the AA.

In the AA new ferrite pick-ups will improve precooling at higher antiproton fluxes and a series of improvements to the cooling electronics are under way. A new injection damper should improve injection of the antiprotons into the PS. In the SPS, the number of colliding bunches will be increased from the present three per beam, the low beta insertion could be made stronger and it might be possible to increase the peak energy of the collider to 310 GeV to increase the W and Z production rates.

Longer term, the possibility of adding a separate ring, an Antiproton Collector, ACOL, has been studied with the aim of accumulating antiprotons at ten times the present rate. This is similar to the scheme at Fermilab where a proton-antiproton collider of up to 1000 GeV energy per beam has become feasible with the operation of their superconducting synchrotron (see page 380).

Although the collider, scheduled to run for physics again in autumn 1984, has yet to reach its somewhat ambitious design performance, this has hardly detracted from the richness of the physics results. Perhaps

never has a new energy range given so many important new results so quickly. A fitting tribute to the inventiveness, skill and ingenuity of the machine physicists who made it all happen.

UA1 and UA2 represent the accumulation of many years of knowledge and experience in the design, construction and operation of particle physics experiments.

The CERN Intersecting Storage Rings (ISR), a masterpiece of a machine, was built ahead of its time in the sense that only towards the end of its lifetime has it been equipped with detectors that do justice to the available physics.

The designers of the UA1 and UA2 detectors had no reason to be caught in the same trap. For the SPS proton-antiproton collider, the aim was to have maximum detector capability right from the start, with adequate tracking and calorimetry (energy deposition measurements); maximum solid angle coverage and powerful data handling systems.

Despite their immense size, the two experiments which discovered the W and Z particles are not readily visible to a visitor to the CERN site. The proton-antiproton collisions which the experiments study take place underground in the ring of the SPS machine, and the detectors are housed in deep caverns.

The 7-kilometre underground SPS ring was designed and built for 'fixed-target' experiments. For this research, high energy proton beams are made to fly off tangentially from the ring. These beams provide the particles which feed the experiments, installed in large, relatively easily accessible experimental halls. Viewed from the elevated gangways, these CERN experimental halls resemble aircraft hangars, but with beamlines and detectors replacing aircraft. The UA1 and UA2 underground halls look very different, but are of the portent of things to come at LEP and other giant new machines to supply colliding particle beams.

Detectors studying colliding beams have to surround the region

On 1 July, Herwig Schopper toasts CERN's achievements at a crowded party to celebrate the end of the epic 1983 antiproton run in the SPS.

(Photo CERN 39.7.83)



A view of the UA1 detector during installation. The two halves of the main magnet/hadron calorimeter are drawn apart, showing inside the elements of the electromagnetic calorimeter surrounding the cylindrical space to be occupied by the inner tracking chamber. When assembled, most of the UA1 detector is covered by its large outer slabs of muon detectors.

(Photo CERN 229.2.81)

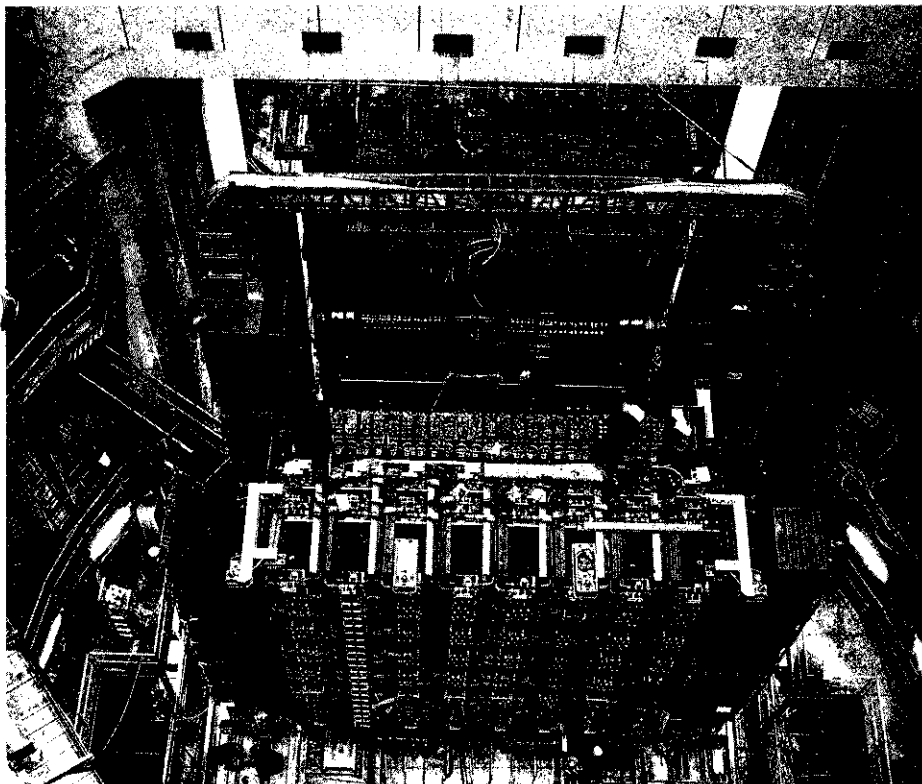

where the beams are brought together. Simply to get the envisaged detectors into the SPS ring would have demanded a mammoth effort of construction and engineering. As if the task of installing a 2000-ton detector with fraction of a millimetre precision in a confined underground space was not enough, there were other restrictions. At the SPS, collider physics would not replace fixed target operation. While the collider experiments were assembled, the machine would continue to operate, and even once the detectors were commissioned, the machine would run alternate periods of fixed target and collider physics according to a prearranged schedule.

Thus the underground caverns had to be made large enough to provide room for the completed detectors to be positioned in the ring, plus enough 'garage' space so that they could be assembled without having to shut

down the machine. The detectors could be rolled back when a period of data-taking was completed and the SPS reverted to fixed-target operation. In these underground garages and shielded by movable walls, the experimenters could assemble apparatus or tinker with their detector, only several feet away from the intense high energy proton beams in the SPS.

The countryside around CERN is far from flat. Although the two experiments are only about one kilometre distant in the SPS ring, the beampipe for UA1's collisions is about 20 metres below the surface, while that for UA2 is some 50 metres underground. The civil engineering for the UA1 premises which began in 1979 used the 'cut and cover' method, while the aptly named 'cathedral' for UA2 was excavated from within.

While the earthmoving and exca-

vating teams began work, a vast physics effort was being mobilized across Europe. Responsibility for the various components of the UA1 and UA2 detectors was delegated to the different research centres in the collaborations, including of course CERN.

Literally hundreds of man-years of heroic effort went into the design, assembly and testing of the thousands of units for the various sub-assemblies of the detectors. Wire by wire, and crate by crate, the electronics grew, and piece by piece the equipment for the detectors came together. The high efficiency attained during the 1983 run (80 per cent) bears witness to the thoroughness of this preparation and ground-work.

The logistics of this work were far-reaching, and sometimes had to overrule physics requirements. The size of some components, for example, was found to be limited by the transport and handling services available.

In both detectors, different types of particles are identified and studied by looking at their behaviour as they pass through successive layers of the apparatus, each of which has a specific function.

Another problem is posed by the rarity of the phenomena being sought. To be sure of catching a few Z particles over a period of about two months, the detectors would have to be exposed to a few thousand proton-antiproton collisions per second. To examine all this data in detail at once was out of the question, and both experiments use 'triggers' — pre-programmed selection criteria which ensure that potentially valuable physics is recorded on special magnetic tapes for subsequent analysis. Thanks to skilful triggering and subsequent data handling, the captured information can be filtered

Cross-section of the UA1 detector. The collision region is surrounded in turn by the central tracking detector, the electromagnetic calorimeter, the magnet/hadron calorimeter and the muon detectors. On either side are the forward and 'very forward' detectors covering particles emerging close to the beam pipe. Not shown are the 'very very forward' detectors ('Roman pots'), some 20 metres from the central detector.

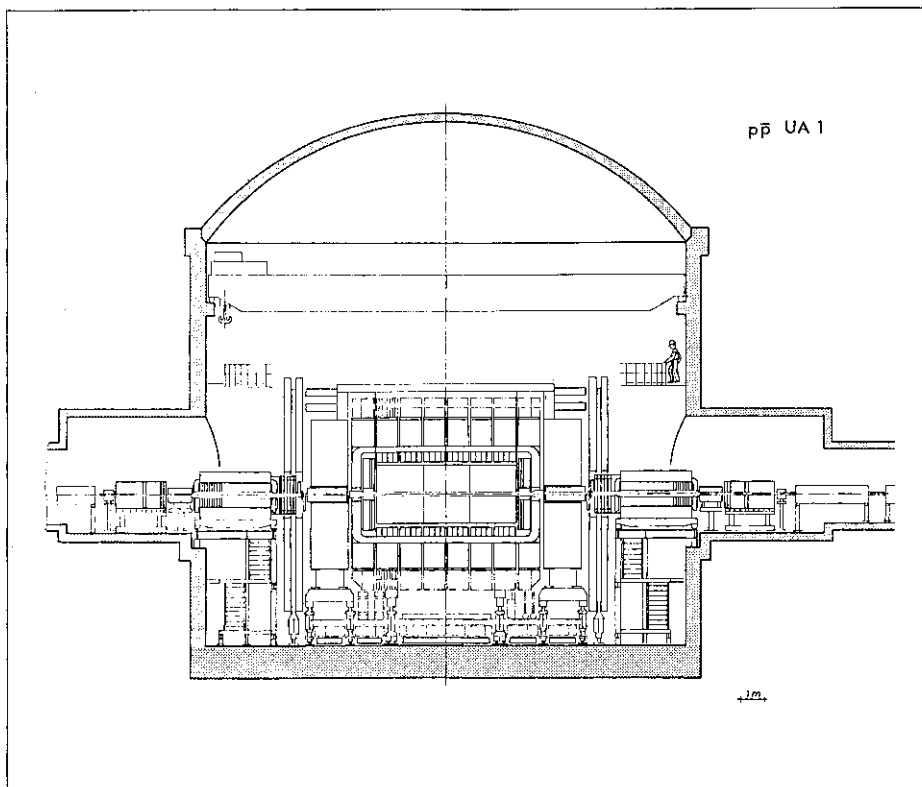

Portrait of UA1

Aachen Technische Hochschule
muon chambers

Annecy (LAPP)
'bouchons' (electromagnetic calorimeter end-caps)

Birmingham
hadron calorimeter, trigger processor

CERN
magnet, compensators, central detector, experimental area, computing, overall coordination

Queen Mary College, London
hadron calorimeter, trigger processor

Paris, Collège de France
forward detectors

Riverside, University of California
'very very forward' detectors

Rome
'very forward' detectors

Rutherford Appleton Laboratory
hadron calorimeter, trigger processor

Saclay
'gondolas' (electromagnetic calorimeter)

Vienna
electromagnetic calorimeter electronics and phototubes

This list is not exhaustive, and covers only the initial configuration of the UA1 detector. Helsinki joined later and Harvard and Wisconsin are also contributing to ongoing development.

and analysed even while the experiments are still running.

Most interest lies in the triggers which select out those events producing particles flying out at large angles to the direction of the colliding beams, as these particles characterize the violent frontal collisions which shake the constituents of the protons and antiprotons.

The UA1 experiment

Carlo Rubbia, leader of the UA1 team, describes his immense detector as 'a series of boxes, each one doing what the previous one couldn't do' — a modest description of some 2000 tons of sophisticated precision apparatus packed with advanced technology!

The UA1 detector was designed to cope with large numbers of particles, collecting 'unbiased' information from collision products collected

over a maximum solid angle. Particle energies are measured both by their curvatures in the internal magnetic field, and by energy deposition (calorimetry). Both electrons and muons are sought.

The 7000 gauss magnetic field is supplied by an 800-ton conventional electromagnet using thin aluminium coils and enclosing a region of 85 cubic metres. Inside the magnet and surrounding the beam pipe carrying the particles are six shells of drift chambers containing 6000 sense wires with image readout, providing a reconstruction of the emerging particle tracks in a cylindrical volume 6 m long and 2.6 m in diameter around the beam crossing point. The reconstructions have an uncanny resemblance to classical bubble chamber tracks.

Surrounding this central detector inside the magnet are the 'gondolas' — 48 crescent-shaped modules of

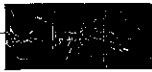

The UA2 detector, showing the finely segmented barrel-like central detector and the large magnetic spectrometers on either side.

(Photo CERN 293.3.82)

lead-scintillator sandwich to catch electromagnetic energy.

The outer hadron calorimeter gauges energy flow when particle densities become too great for magnetic analysis. It consists of scintillator slabs and associated instrumentation fitted between the C-shaped iron slabs of the magnet return yoke. Both the electromagnetic and hadronic calorimeters are closed by end-caps.

Muons transversing all this are picked up in large slab-like arrays of drift chambers which cover the entire apparatus, giving it a deceptively uninteresting box-like appearance. These muon chambers alone required some 30 kilometres of extruded aluminium! To supplement the detection capabilities of the main detector, additional equipment is installed in the forward/backward regions around the beam pipe on either side of the main detector.

A sophisticated microprocessor-based data handling system has been developed which selects out potentially interesting data and copes with the enormous amounts of information produced by each measured collision (see April issue, page 82).

UA2

The search for W and Z particles was high on the list of priorities in the UA2 design, which concentrates on decays producing electrons. Lead/scintillator sandwich counters identify electrons over a wide solid angle.

Particles emerging from the collisions are picked up in the inner ver-

Schematic diagram of the UA2 detector. The inner vertex detector was made by Orsay, the forward drift chambers by Copenhagen and Pavia, the forward calorimeters by Saclay, the forward multi-tube proportional counters (MTPC) by Bern, and the large central calorimeter and the toroid coils by CERN.

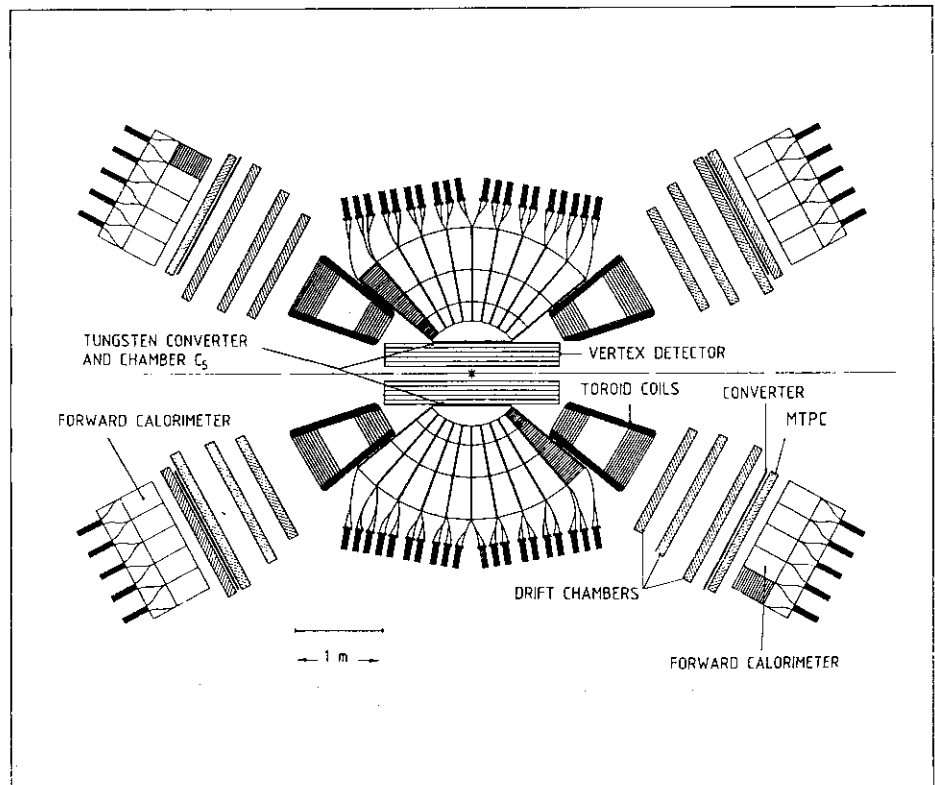
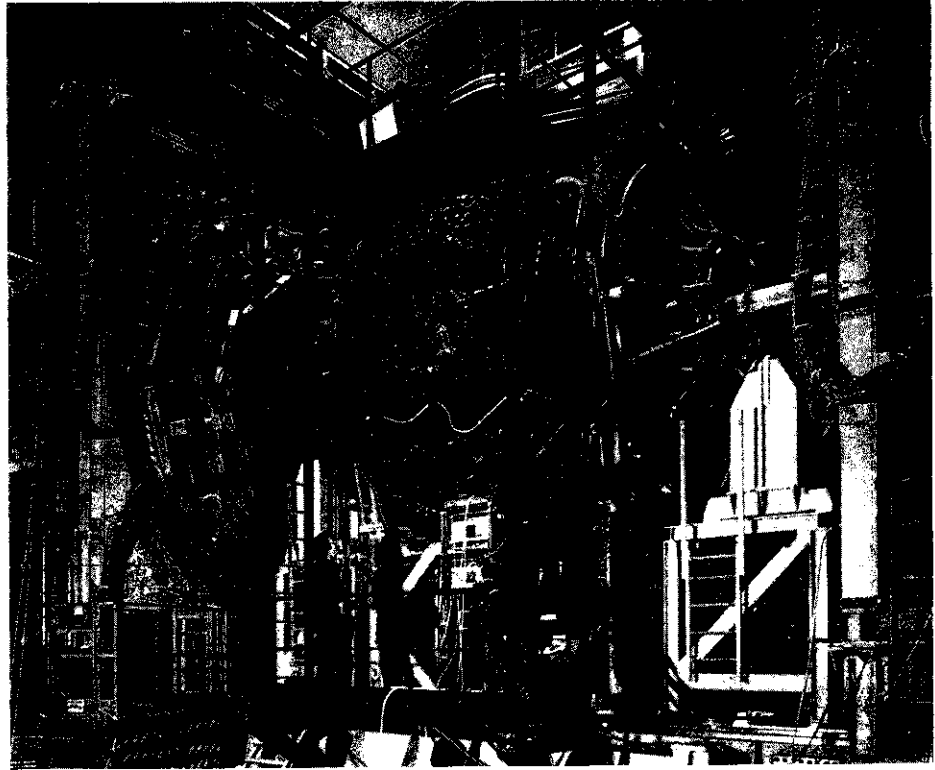

January 1983. One of the events found by the UA1 detector from the October-December 1982 run producing a high transverse energy electron (arrowed). This particle is moreover produced more or less back-to-back with 'missing energy', indicative of the emission of an invisible neutrino. The electron and the neutrino are the decay products of a W particle.

tex detector, equipped with interleaved proportional chambers and drift chambers. From the reconstructed particle tracks, the position of the interaction can be pinpointed.

Surrounding this vertex detector are the central electromagnetic and hadronic calorimeters, segmented into 240 cells, each pointing towards the centre of the interaction region. Each of these cells is divided into electromagnetic (lead/scintillator) and hadronic (iron/scintillator) compartments.

The annular regions on either side of the central detector are equipped with magnetic analysis and segmented arrays of lead-scintillator shower counters for electromagnetic energy measurement, and drift and proportional tube chambers for electron localization.

During its initial runs in 1981 and 1982, the UA2 central calorimeter had a 'wedge' removed to accommodate a magnetic spectrometer which measured the level of neutral pion production.

Hunting Ws and Zs

The new experiments in the SPS ring had their first tentative glimpse of 540 GeV proton-antiproton collisions in the summer of 1981. The first task was to make an initial survey of particle behaviour in this newly available energy range. Cosmic ray experiments had previously reported unexplained behaviour, with events containing large numbers of long-lived particles but remarkably few neutral pions. Physicists were eager to see if this could be reproduced under laboratory conditions. However neither UA1 nor the big streamer chambers of the UA5 experiment (Bonn/Brussels/Cambridge/CERN/Stockholm) saw anything radically new.

For the second antiproton run later

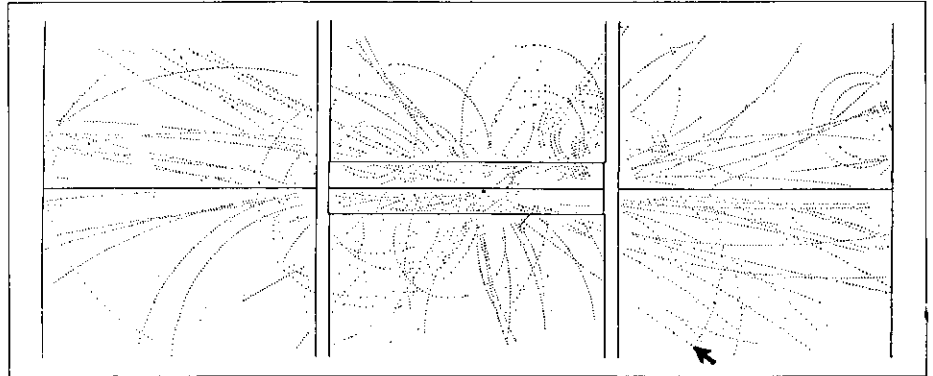

in 1981, the UA5 detector was replaced by UA2, and the UA1 central detector came into action for the first time. In those days, proton-antiproton collision rates were low (best luminosity $5.2 \times 10^{27} \text{ cm}^{-2} \text{ s}^{-1}$), and finding W and Z particles was out of the question. But both UA1 and UA2 were able to make valuable contributions to the study of particle 'jets' — well-defined clusters of emerging particles, interpreted as the results of violent collisions between the quarks and gluons hidden deep inside the protons and antiprotons.

Evidence for such jets had been seen in experiments at lower energy, but the higher energies available in the SPS collider made the jets stand out unmistakably from background effects due to other processes. The SPS collider results on jet production were among the physics highlights of 1982. Another initial collider success was the charting of reaction rates (cross-sections) by the UA4 experiment (Amsterdam / CERN / Genoa / Naples / Pisa), installed with UA2, to see how these compared with what was known from lower energies. (UA1 also measures these cross-sections.)

Meanwhile the SPS and the experiments prepared for a major antiproton run, scheduled for the spring of 1982. Then disaster struck. While setting up, the UA1 detector fell victim to a dirty compressed air supply

which contaminated the delicate components of the inner detector. Spirits were low when the detector had to be painstakingly dismantled for cleaning and the run was postponed.

However this setback paid unexpected dividends. Instead of two separate runs, 1982 SPS antiproton operations were merged into one block, which began in October. This was to make for valuable savings in setting-up and running-in.

After a modest start which further tried experimenters' patience, things quickly began to improve. Soon the SPS was supplying what was to become the standard diet of three circulating bunches of protons and of antiprotons. Collision rates improved to give luminosities of around $10^{28} \text{ cm}^{-2} \text{ s}^{-1}$, and experimenters were seen going around with wide smiles. They knew they were logging lots of data with low backgrounds, just what they needed to find W particles.

Luminosity continued to improve, reaching a record level of 5×10^{28} . By the end of the run, UA1 and UA2 had each intercepted a major proportion of the 28 inverse nanobarns of integrated luminosity to which they had been exposed. According to the theory, here was enough data to provide some charged W particles. Eagerly the experimenters turned to the analysis of their data.

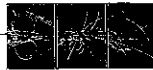

The signature of a W particle, from the 1982 run, as recorded in the UA2 detector. A lone high transverse momentum electron towers over a barren landscape.

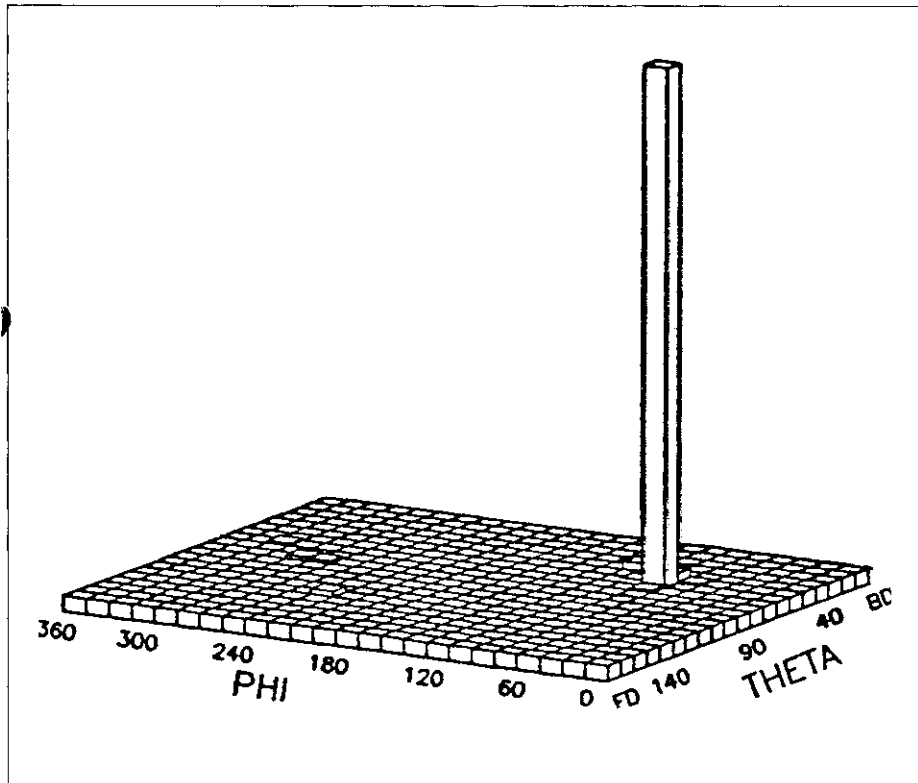

Even during the run, it had been clear that they were seeing something in the events 'triggered' by energetic electrons. After off-line analysis, the UA1 and UA2 teams found several examples where, amongst the clutter of particles emerging from the collisions, a lone high energy electron had been spat out at a wide angle to the beam direction (high transverse momentum). This isolated electron was found to be roughly back-to-back with 'missing' energy in the calorimeters with no visible associated particle track, hinting at a neutrino.

Some thousand million collisions had been seen by the detectors in the 1982 run, but of these, only about one tenth of a per cent were violent enough to provide the right conditions to produce W s and Z s. Each of these selected collisions produced enough detector information to fill a large telephone directory. Thus it was a dazzling feat of detector know-how and data handling skill by both the experiments to sift through this mass of information so quickly and filter out their interesting events — six at UA1 and four at UA2.

The results were first presented at the Workshop on Proton-Antiproton Collider Physics, held in Rome in January. The explanation of these events was then still only a whisper. At the meeting, Fermilab Director Leon Lederman had confessed to being impressed by 'the speed at which data was analysed and physics achieved out of detectors of unprecedented sophistication, viewing collisions of novel complexity'.

It took the physicists just a few weeks to convince themselves that they had found the signature of a W particle decaying into an energetic electron and a neutrino, carrying energy but invisible. The formal announcement of the discovery of the

OBSERVATION OF SINGLE ISOLATED ELECTRONS OF HIGH TRANSVERSE MOMENTUM IN EVENTS WITH MISSING TRANSVERSE ENERGY AT THE CERN $\bar{p}p$ COLLIDER

The UA2 Collaboration

M. BANNER^f, R. BATTISTON^{g,2}, Ph. BLOCH^f, F. BONAUDI^b, K. BORER^a, M. BORGHINI^b, J.-C. CHOLLET^d, A.G. CLARK^b, C. CONTA^e, P. DARRIHULAT^b, L. DI LELLA^b, J. DINES-HANSEN^c, P.-A. DORSAZ^b, L. FAYARD^d, M. FRATERALI^c, D. FROIDEVAUX^b, J.-M. GAILLARD^d, O. GILDEMEISTER^b, V.G. GOGGI^e, H. GROTE^b, B. HAHN^a, H. HANNI^a, J.R. HANSEN^b, P. HANSEN^c, T. HIMEL^b, V. HUNGERBÜHLER^b, P. JENNI^b, O. KOFOED-HANSEN^c, E. LANÇON^f, M. LIVAN^{b,c}, S. LOUCATOS^f, B. MADSEN^c, P. MANI^a, B. MANSOULIÉ^f, G.C. MANTOVANI^f, L. MAPELLI^b, B. MERKEL^d, M. MERMIKIDES^b, R. MÖLLERUD^c, B. NILSSON^c, C. ONIONS^b, G. PARROUR^{b,d}, F. PASTORE^{b,c}, H. PLOTHOW-BESCH^{b,d}, M. POLVEREL^f, J.-P. REPELLIN^d, A. ROTHENBERG^b, A. ROUSSARIE^f, G. SAUVAGE^d, J. SCHACHER^a, J.L. SIEGRIST^b, H.M. STEINER^{b,3}, G. STIMPFL^b, F. STOCKER^a, J. TEIGER^f, V. VERCESI^e, A. WEIDBERG^b, H. ZACCONE^f and W. ZELLER^a

^aLaboratorium für Hochenergie physik, Universität Bern, Stillerstrasse 5, Bern, Switzerland
^bCERN, 1211 Geneva 23, Switzerland

^cNiels Bohr Institute, Blegdamsvej 17, Copenhagen, Denmark

^dLaboratoire de l'Accélérateur Linéaire, Université de Paris-Sud, Orsay, France

^eDipartimento di Fisica Nucleare e Teorica, Università di Pavia and INFN, Sezione di Pavia, Via Bassi 6, Pavia, Italy

^fCentre d'Etudes nucléaires de Saclay, France

Received 15 February 1983

We report the results of a search for single isolated electrons of high transverse momentum at the CERN $\bar{p}p$ collider. Above 15 GeV/c, four events are found having large missing transverse energy along a direction opposite in azimuth to that of the high- p_T electron. Both the configuration of the events and their number are consistent with the expectations from the process $\bar{p} + p \rightarrow W^+ + \text{anything}$, with $W \rightarrow e + \nu$, where W^+ is the charged Intermediate Vector Boson postulated by the unified electroweak theory.

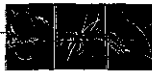

EXPERIMENTAL OBSERVATION OF LEPTON PAIRS OF INVARIANT MASS
AROUND 95 GeV/c² AT THE CERN SPS COLLIDER

UA1 Collaboration, CERN, Geneva, Switzerland

G. ARNISON¹, A. ASTBURY¹, B. AUBERT^b, C. BACCI¹, G. BAUER¹, A. BÉZAGUET^d,
R. BÖCK^d, T.J.V. BOWCOCK¹, M. CALVETTI^d, P. CATZ^b, P. CENNINI^d, S. CENTRO^d,
F. CERADINI^{d,i}, S. CITTOLIN^d, D. CLINE¹, C. COCHET^k, J. COLAS^b, M. CORDEN^c,
D. DALLMAN^{d,j}, D. DAU², M. DeBEER^k, M. DELLA NEGRA^{b,d}, M. DEMOULIN^d,
D. DENEGRI^k, A. Di CIACCIO¹, D. DiBITONTO^d, L. DOBRZYNSKI^k, J.D. DOWELL^c,
K. EGGERT^a, E. EISENHANDLER¹, N. ELLIS^d, P. ERHARD^a, H. FAISSNER^a, M. FINCKE²,
G. FONTAINE^g, R. FREY^h, R. FRÜHWIRTH¹, J. GARVEY^c, S. GEER^k, C. GHESQUIÈRE^e,
P. GHEZ^b, K. GIBONI^a, W.R. GIBSON¹, Y. GIRAUD-HÉRAUD^k, A. GIVERNAUD^k, A. GONIDEF^b,
G. GRAYER¹, T. HANSL-KOZANECKA^a, W.J. HAYNES¹, L.O. HERTZBERGER³, C. HODGES^h,
D. HOFFMANN^a, H. HOFFMANN^d, D.J. HOLTHUIZEN², R.J. HOMER^c, A. HONMA^f, W. JANK^d,
G. JORAT^d, P.I.P. KALMUS¹, V. KARIMÁKI^c, R. KEELER¹, I. KENYON^c, A. KERNAN^h,
R. KINNUNEN^e, W. KOZANECKI^h, D. KRYN^{d,k}, F. LACAVA¹, J.-P. LAUGIER^k, J.-P. LEES^b,
H. LEHMANN^a, R. LEUCHS^a, A. LÉVÉQUE^{k,d}, D. LINGLIN^b, E. LOCCI^k, J.J. MALOSSE^k,
T. MARKIEWICZ^d, G. MAURIN^d, T. McMAHON^c, J.-P. MENDIBURU^k, M.-N. MINARD^b,
M. MOHAMMADI¹, M. MORICCA¹, K. MORGAN^h, H. MUIRHEAD^a, F. MULLER^d, A.K. NANDI¹,
L. NAUMANN^d, A. NORTON^d, A. ORKIN-LECOURTOIS^e, L. PAOLUZI¹, F. PAUSS^d,
G. PIANO MORTARI¹, E. PIETARINEN^c, M. PIMIÁ^e, A. PLACCI^d, J.P. PORTE^d,
E. RADERMACHER^a, J. RANDELL^h, H. REITHLER^a, J.-P. REVOL^d, J. RICH^k,
M. RUSSENBEEK^d, C. ROBERTS¹, J. ROHLF^d, P. ROSSI^d, C. RUBBIA^d, B. SADOULET^d,
G. SAJOT^g, G. SALVI¹, G. SALVINI¹, J. SASS^k, J. SAUDRAIX^k, A. SAVOY-NAVARRO^k,
D. SCHINZEL^d, W. SCOTT¹, T.P. SHAH¹, M. SPIRO^k, J. STRAUSS¹, J. STREETS^c,
K. SUMOROK^d, F. SZONCISO¹, D. SMITH^h, C. TAO³, G. THOMPSON¹, J. TIMMER^d,
E. TSCHESLOG^a, J. TUOMINIEMI^e, B. Van EIJK³, J.-P. VIALLE^d, J. VRANA^g,
V. VUILLEMIN^d, H.D. WAHL¹, P. WATKINS^c, J. WILSON^c, C. WULZ¹, G.Y. XIÉ^d,
M. YVERT^b and E. ZURFLUH^d

Aachen^a - Anney (LAPP)^b - Birmingham^c - CERN^d - Helsinki^e - Queen Mary College, London^f -
Paris (Coll. de France)^g - Riverside^h - Rome¹ - Rutherford Appleton Lab.³ - Sackay (CEN)^k - Vienna^h Collaboration

Received 6 June 1983

We report the observation of four electron-positron pairs and one muon pair which have the signature of a two-body decay of a particle of mass ~ 95 GeV/c². These events fit well the hypothesis that they are produced by the process $\bar{p} + p \rightarrow Z^0 + X$ (with $Z^0 \rightarrow e^+ + e^-$ or $\mu^+ + \mu^-$), where Z^0 is the Intermediate Vector Boson postulated by the electroweak theories as the mediator of weak neutral currents.

¹ University of Wisconsin, Madison, WI, USA.

² University of Kiel, Fed. Rep. Germany.

³ NIKHEF, Amsterdam, The Netherlands.

⁴ Visitor from the University of Liverpool, England.

W particle by the UA1 team was made at CERN on 25 January and later confirmed by UA2. As predicted by the theory, its mass was around 80 GeV.

The next step was to track down the companion Z^0 , the carrier of the neutral current of the weak interaction. However the theory said that these would be ten times rarer than the Ws, and at least several times the amount of data collected in the 1982 run would be required to give the experimenters a good chance of finding some.

The SPS operations team were set a goal of 100 inverse nanobarns, roughly four times what was achieved in 1982. Were people being too optimistic in hoping to find the Z^0 so soon after the highly successful 1982 run, which had already smashed all records?

The 1983 SPS antiproton run began on 12 April, again modestly. But improved techniques and methods began to pay dividends. Magnificent reliability assured a steady supply of the precious antiprotons. Luminosities crept higher and a record figure

of 1.6×10^{29} cm⁻² s⁻¹ was achieved, more than a hundred times what was seen in the pioneer runs in 1981. The 100 inverse nanobarn target was duly reached on 6 June, one full month before the end of the run!

The signature of a Z^0 was expected to be much clearer than that of the W. There would be no tricky missing energy to look for. The experiments were looking for clear electron-positron pairs (and, in the case of UA1, oppositely charged muon pairs), carrying more energy than had ever been seen before.

The UA1 team triumphantly unearthed a Z^0 candidate event on 4 May, from data recorded just a few days before. A first estimate of its mass was around 100 GeV, in the region where it was expected. But this first Z candidate was worrisome as one of its electron tracks looked as though it was accompanied by an energetic photon.

But cleaner examples of Z^0 decay into electron and positron (and into two muons) arrived from UA1 in the ensuing weeks. On 1 June, the formal announcement of the discovery of the Z^0 particle was made at CERN.

After the end of the 1983 antiproton run on 3 July, the UA1 and UA2 experiments had between them about a dozen Z^0 s, centred around 93 GeV, and about a hundred Ws at 81 GeV. As well as W decays producing a lone electron plus neutrino, UA1 has also seen decays producing a muon plus neutrino. The analysis of the data is continuing, and more events are turning up.

But whatever else the UA1 and UA2 experiments may find in the SPS collider, it is clear that a new chapter can be added to the history of science. With LEP and other big machines now being built or planned, we are entering a new era of physics.

Groundbreaking for LEP

After arriving at CERN by helicopter for the official LEP groundbreaking ceremony on 13 September, President François Mitterrand of France (left) was greeted by CERN Director-General Herwig Schopper. The other principal guest of honour, President Pierre Aubert of Switzerland (right), had arrived by car just a few minutes earlier.

(Photo CERN 50.9.83)

On 13 September, CERN found itself once more in the international spotlight when President François Mitterrand of France and President Pierre Aubert of Switzerland arrived for the official 'groundbreaking' ceremony for the 27-kilometre ring of the LEP electron-positron collider.

As well as the Presidents of the two CERN host states under whose territory LEP will be constructed, there were ranking representatives of the CERN Member States, together with those of other countries who will take part in the first LEP experiments, expanding further the already large community of CERN users.

For weeks before the ceremony, CERN was bowed under the weight of the preparations for the big day, which witnessed pomp and spectacle on a scale to match LEP itself. Hundreds of guests had to be welcomed, conducted around, seated, entertained and protected. In addition, there was the throng of attendant press and TV crews which inevitably accompanies a presidential visit.

As if this was not enough, the whole operation took place on both sides of the Franco-Swiss international boundary. The participants found themselves crossing and re-crossing the frontier many times during the course of the day. Sometimes the easiest way to ascertain which country one was in was by looking at the uniforms of the armed security guards patrolling the area.

At 11.30, President Mitterrand and his entourage arrived at CERN by helicopter, to be greeted by President Aubert of Switzerland, who had arrived a few minutes earlier, and by CERN Director-General Herwig Schopper. The two heads of state



Signing the official visitors' book.

(Photo CERN 325.9.83)

With LEP Project Director Emilio Picasso (left) the Presidents and the Director-General watch as (below) ground is broken for LEP.

(Photos CERN 195/202.9.83)

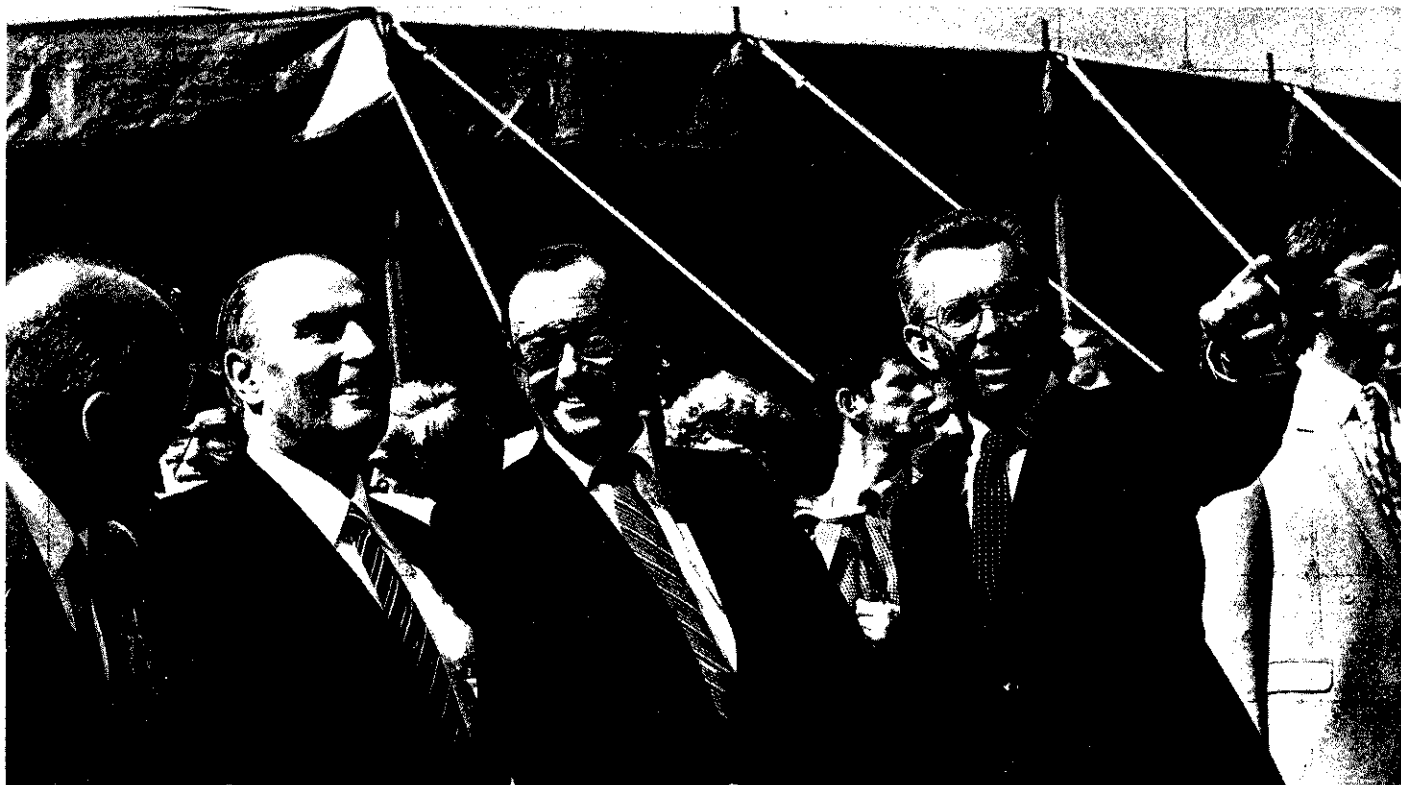

climbed into a limousine for the short journey to the nearby LEP civil engineering site, where an enormous multicoloured marquee had been erected to house the hundreds of guests, CERN staff and press attending the ceremony. The Corps de Musique of the Geneva Landwehr struck up in style as the Presidents arrived and were greeted by local French and Swiss authorities.

Inside the marquee, Herwig Schopper took the podium first to welcome his guests and proudly explained how the construction of LEP underlined CERN's unique position as a world-class centre of scientific and technological excellence. However it was left to the two Presidents to continue where CERN's own modesty had left off. Both paid tribute to CERN's work and emphasized its role in strengthening European science and cooperation, and the world-wide recognition that this has

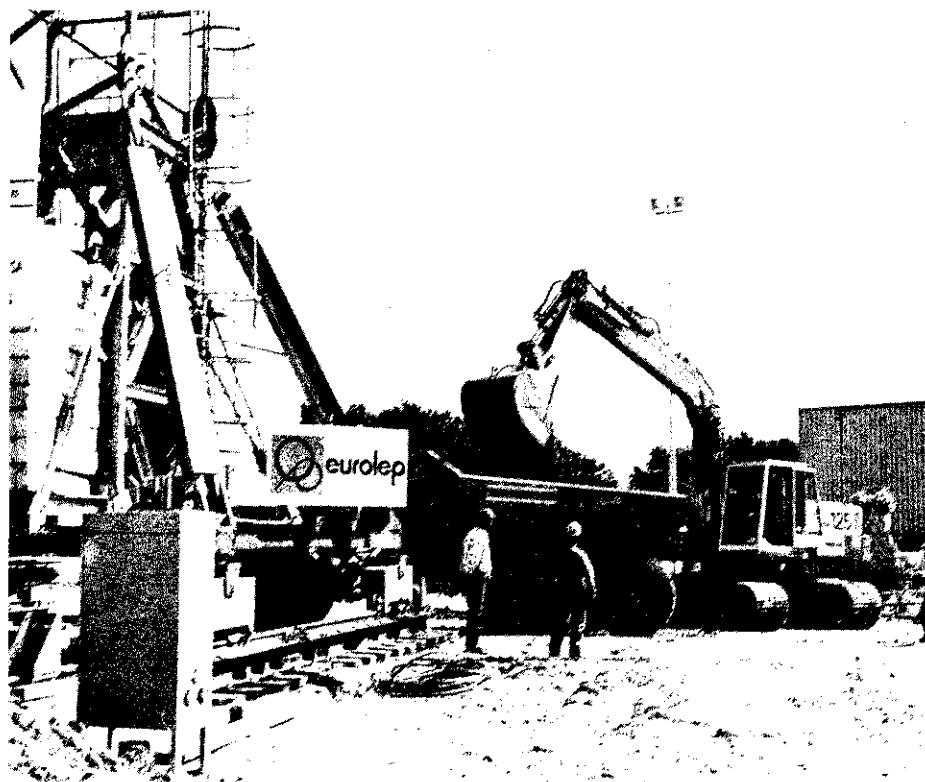

Former President of CERN Council Jean Teillac (right) explains some of the mysteries of the UA1 detector.

(Photo CERN 331.9.83)



Everyone seemed to be impressed and happy with the course of the day's events. If the LEP project itself goes equally well, then 1988 could see an even more impressive inauguration ceremony. The largest scientific machine in the world will be ready to go into action.

brought. They wished CERN, and the LEP project in particular, well.

Then began a short but symbolic ceremony. The Presidents were given a commemorative parchment and a copy of the text on the front of the LEP foundation stone. These documents they rolled up and gave back to be sealed in a metal container, which was slipped into a hole in the foundation stone. The two heads of state took turns in plugging the hole with mortar.

The hole was then covered by a plaque inscribed with diagrams and symbols summarizing our present understanding of the way the Universe works. To the archaeologists who will one day find it, these symbols may well indicate ignorance rather than understanding!

LEP Project Director Emilio Picasso and Henri Laporte, head of LEP civil engineering, presented the Presidents with two keys to pass in turn

to the drivers of a contractor's lorry and a mechanical shovel standing ready nearby. The Presidential party watched as ground was broken. The shovel took its scoop of soil and deposited it in the waiting truck.

As the assembled crowd dispersed, the Presidential party was conducted round a specially-prepared exhibition of LEP and other aspects of CERN's work.

After lunch and toasts, the Presidents visited the UA1 detector, 20 metres underground and drawn back into its garage position adjacent to the SPS ring. A separate ministerial party followed, and went on into the SPS ring beyond, symbolically crossing the Swiss-French frontier underground, before arriving at the underground hall housing the UA2 detector.

For the CERN staff a mammoth LEP party was laid on which continued far into the night.

On target

The initial phase of LEP operation was designed for electron and positron beams of 50 GeV, providing a total collision energy of 100 GeV. The discovery this year of the Z^0 at some 92 GeV is exactly where it was predicted by the electroweak theory, and is within LEP's grasp. The new machine will provide a veritable 'factory' for churning out Z particles, and will explore the new electroweak picture of Nature under conditions where the strengths of the 'weak' and electromagnetic components become comparable.

Around the Laboratories

Groundbreaking for the Tevatron antiproton source at Fermilab on 16 August.



FERMILAB Going for antiprotons

Ground was broken on 16 August at Fermilab for the Antiproton Source, one element in a multi-phased attack that should lead to the study of 2 TeV proton-antiproton collisions by 1986 with a luminosity exceeding $10^{30} \text{ cm}^{-2} \text{ s}^{-1}$.

The Tevatron I project now under way consists of the adaptation of the Energy Doubler to serve as a 1 TeV storage ring, modification of the existing Main Ring for use in antiproton production, and construction of the Antiproton Source. The project also includes the construction of two experimental areas, one at B0 and another at the D0 straight section in the 1 TeV ring. The project involves collaborators from the Institute of Nuclear Physics at Novosibirsk, Ar-

gonne National Laboratory, the University of Wisconsin, and Lawrence Berkeley Laboratory.

Construction is also well under way for a large general-purpose Collider Detector. It will be located in the detector hall of the experimental building at the B0 straight section. The Collision Hall was completed in March, one month ahead of schedule, and turned over to the Accelerator Division. The rest of the building has now been completed and installation of equipment is starting. Both the Energy Saver and Main Ring beams now traverse the 167-ft long enclosure. The D0 construction is scheduled to begin in the summer of 1985. Specialized experiments such as small-angle elastic scattering and monopole searches are planned for other straight sections.

Colliding beams at Fermilab calls for some intricate choreography of rings and particles: the Main Ring will

receive one batch of protons from the Booster, accelerate it to 120 GeV, compress this in time and extract it onto a target. Secondary antiprotons will be collected and transported to a Debuncher ring where they will be decompressed and cooled before being transferred to an Accumulator ring. The Accumulator will be able to store antiprotons for many hours. When enough antiprotons have been collected, they will be shipped back to the Main Ring for acceleration to 150 GeV and transfer to the Doubler Ring.

Since the beam manipulation required to reduce the antiproton momentum spread is a relatively violent process, the antiprotons will first be sent to a Debuncher ring and then accumulated in a second ring, the Accumulator, rather than using the Debuncher for accumulation. The separation of the two functions in two rings makes it possible to opti-

Diagram of the antiproton system at Fermilab showing the position of the source and the triangular 'rings' of the Debuncher and Accumulator.

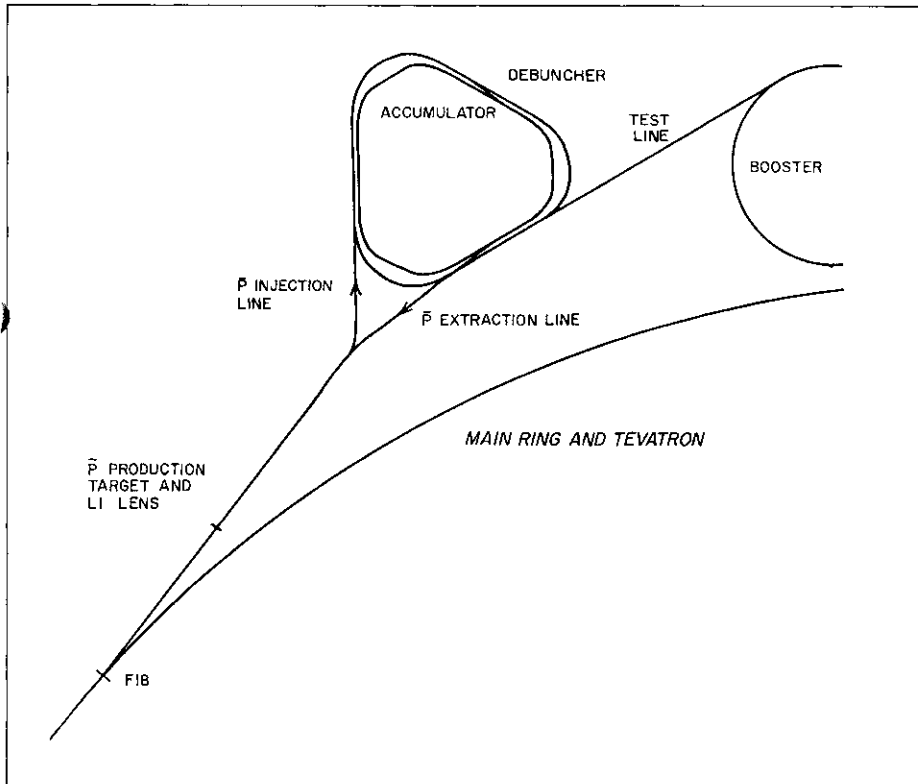

mize each ring for its own purpose. The ability to do fast betatron cooling in the Debuncher once the debunching is completed is an additional benefit from two rings.

The cooling systems which will be used are similar in principle to the systems developed at CERN for the Antiproton Accumulator ring. They differ primarily in implementation since the cooling rate of 10^{11} antiprotons/hr can be achieved only if the system bandwidth is in the microwave region. CERN is now looking at the new technology that has been developed at Fermilab. The Fermilab system requires a high dispersion straight section for the pickups and a zero dispersion straight section for the kickers. The stack tail betatron systems require high dispersion regions for both pickups and kickers, leading to the striking triangular 'ring' structure.

The most efficient way to produce

antiprotons at Fermilab is to bombard a fixed target with high energy protons from the Main Ring. When the energy dependence of the Main Ring cycle time is taken into consideration, there is a broad maximum in the antiproton flux near a proton energy of 150 GeV. Since it is desirable to locate the Source near the Booster, the proton beam will be extracted from the F17 medium straight section in the Main Ring. This choice will limit the proton energy to 120 GeV, but the antiproton flux will be down only slightly from the optimum value. The yield of antiprotons with momentum has a broad maximum at 10 GeV. The antiprotons will be collected and cooled at 8.9 GeV, very nearly the optimum choice of antiproton momentum and the standard injection momentum into the Main Ring.

The sequence for colliding beams proceeds in seven stages.

Stage 1 — Proton Acceleration for Antiproton Production. Every two seconds, one Booster batch containing 2×10^{12} protons will be accelerated in the Main Ring to 120 GeV and held at that energy while the r.f. manipulation in Stage 2 is carried out.

Stage 2 — Preparation of Protons for Targeting. The r.f. voltage in the Main Ring will be decreased so that each proton bunch spreads out in time. Just prior to extraction the r.f. voltage will be increased rapidly so that each proton bunch rotates in phase space, thereby drastically reducing the time spread. The train of short bunches will be extracted from the Main Ring at F17 when the time spread is at a minimum.

Stage 3 — Antiproton Production and Transport. The proton bunches will strike a tungsten target, producing a train of 82 equally short antiproton bunches. A collector has been devised that uses a lithium lens, similar to one developed at Novosibirsk, to collect the antiprotons produced within a cone of 60 milliradians. The active part of the lens is a 15-cm long by 2-cm diameter lithium cylinder. The peak focusing gradient will be 1000 T/m. The lens was filled with lithium for the first time in July and has now been shipped to CERN for tests. On each cycle 7×10^7 antiprotons will be collected by the lithium lens and transported by the antiproton injection lines to the Debuncher.

Stage 4 — Bunch Rotation in the Debuncher. The antiprotons will be injected into r.f. buckets in the triangular Debuncher. The primary purpose of the Debuncher is to reduce the large momentum spread of the 8 GeV antiproton beam at production to 0.2 per cent or less prior to injection into the Accumulator. After somewhat less than a quarter of a synchrotron oscillation, the r.f. vol-

A lithium lens will be used to collect Fermilab's antiprotons. Initial trials of the lens at CERN have been encouraging.

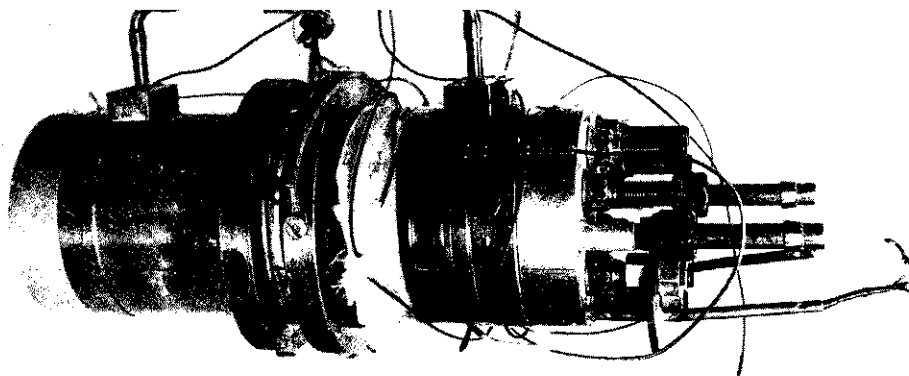

tage will be rapidly decreased to match the bucket to the rotated bunch, and then adiabatically decreased to a few kilovolts.

Stage 5 — Transverse Cooling in the Debuncher. After debunching, the horizontal and vertical transverse emittances will be stochastically cooled in the Debuncher from 20π mm-mrad to less than 7π mm-mrad.

Stage 6 — Antiproton Accumulation and Cooling. The antiprotons will be extracted from the Debuncher and injected into the Accumulator. Successive bunches of antiprotons will be r.f. stacked in the system. Between injection cycles the stack will be stochastically cooled using a system similar to the type developed by CERN for the Antiproton Accumulator ring. The coherent force of the stochastic cooling system will move the fresh batch away from the stacking orbit toward the core of the stack. In four hours, the peak core density will grow to 10^5 antiprotons per eV. The total number of antiprotons in the core will be 4×10^{11} . The experience at the CERN SPS collider indicates that the luminosity lifetime is longest when the proton and antiproton bunches have the same emittance. For that reason, the Antiproton Source betatron cooling systems

have been designed so that the transverse emittance of the antiproton bunches will be the same as the transverse emittance of the proton bunches.

Stage 7. After accumulation is complete, antiproton bunches will be individually extracted from the core, transferred to the Main Ring, accelerated to 150 GeV and injected into the Tevatron. To achieve peak luminosity of 10^{30} cm⁻² s⁻¹ in the Energy

Saver at 2 TeV, the Antiproton Source must be able to accumulate 4×10^{11} antiprotons within the luminosity lifetime. The design luminosity will be obtained by injecting three bunches of protons and three bunches of counter-rotating antiprotons into the Energy Saver. Head-on collisions will take place in the six straight sections. The same number of proton bunches of similar intensity will be prepared in the Main Ring and injected into the Tevatron. All six bunches will then be accelerated to about 1 TeV and the strength of the low beta quads at the collision regions increased in order to create the appropriate conditions for experiments.

The construction of the low-beta system at the interaction area at B0 is nearly complete. The construction of the quadrupole magnets and their cryostat is under way, following the successful testing of the high-gra-



The completed building for the experimental hall at the B0 intersection for the Fermilab antiproton scheme.

dient prototype. The low-beta quads will achieve a gradient of 25 kG/in., compared with 20 kG/in. for normal Energy Saver quadrupoles. These magnets will have a copper to superconducting ratio of 1.3 to 1 rather than the 1.8 to 1 used in the standard Energy Saver quadrupoles.

Work on the Collider Detector is progressing well. It is being built by a consortium including Fermilab, Argonne, Berkeley, Brandeis, Chicago, INFN (Italy), Harvard, Illinois, KEK (Japan), Pennsylvania, Pisa, Purdue, Rutgers, Texas A&M, Tsukuba (Japan), and Wisconsin. Much work has been done in test beams with prototypes of the Collider Detector calorimeters. Production lines have been set up for cutting and shaping scintillator and waveshifter pieces, and an impressive arch thirty feet high has been assembled consisting of twelve central calorimeter wedges (see March issue, page 52). The

mammoth superconducting solenoid, three metres in diameter and 5 metres long, is under construction in Japan. Front-end electronics work is also under way.

The D0 area was originally planned to house small experiments, but the Physics Advisory Committee recommended that it be enlarged in scope, and a series of workshops to study the use of more ambitious detectors in D0. A major calorimetric detector has been approved for construction at D0, and the design of the D0 area is now under way.

At the record collision energies which will be available, the physics rewards might be rich and unexpected.

Inside the Fermilab B0 proton-antiproton collision hall, showing the beam pipes of the Main Ring (top) and the superconducting Tevatron. Work on the detector is progressing well.

(Photos Fermilab)

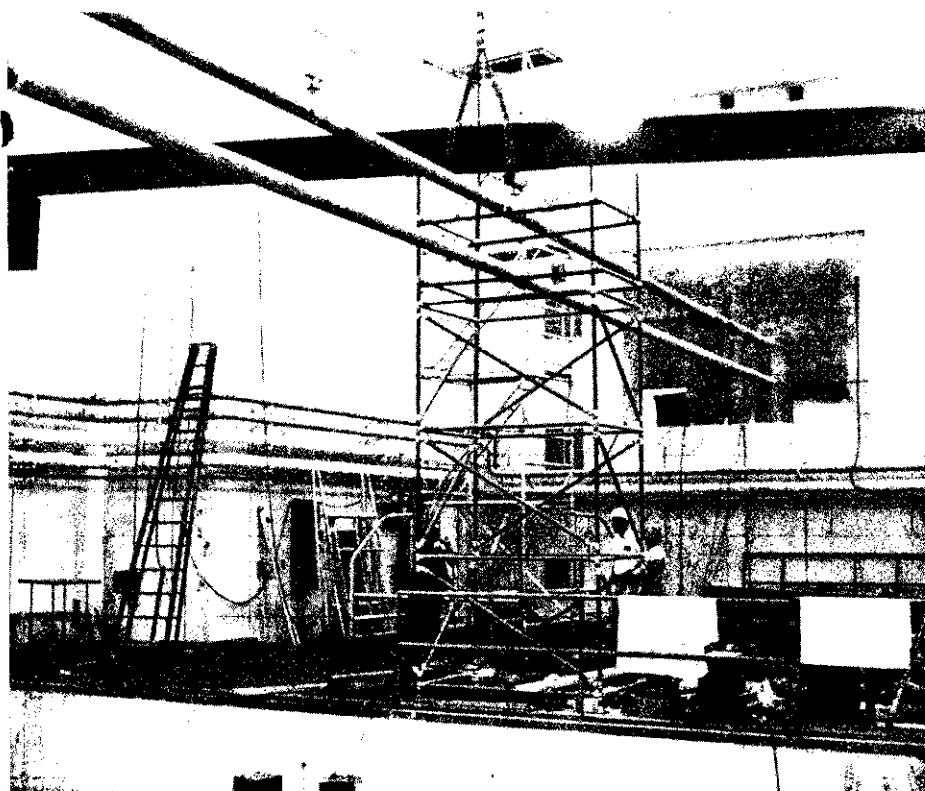

Update on the Doubler/Saver

Since the acceleration of beam to 512 GeV in the superconducting ring of the Tevatron (see September issue, page 251), detailed studies have been carried out to map the parameters of the accelerator, particularly tune, chromaticity, and coupling measurements. On 2 August, when it was felt that the accelerator was sufficiently understood, 512 GeV beam was extracted very smoothly through the extraction channel to the Neutrino line beam dump. Intensities greater than 2×10^{12} protons have been accelerated at a 60 second repetition rate, and extracted with a five second spill. Losses during extraction are low and no beam-induced quenches of the superconductor have occurred. On 13 August 600 GeV beam was accelerated at an intensity of 2×10^{12} protons per pulse. On 15 August the beam energy was raised to 700 GeV.

Beam storage studies were carried out on 19 August. Beam was accelerated to 512 GeV and stored for an arbitrarily chosen flat-top of 800 seconds. Beam loss is very small. No conclusions about lifetime can be made until the flat-top lengths are increased.

Studies continue at 512 GeV before the start of the experimental programme. Increasing the intensity to 10^{13} protons per pulse is the primary goal. Meanwhile, the Switchyard and Experimental Areas are completing their preparations to accept beam.

The peak beam energy will be gradually increased as more experience is gained with the refrigeration and power supply systems.

The Serpukhov hodoscope photomultiplier (HPM) and large aperture Ring Imaging Cherenkov (RICH) counter.

1 – photocathode, 2 – resistive electrode, 3 – permanent magnet, 4 – dynode, 5 – glass housing, 6 – conical reflector, 7 – transparent window, 8 – steel vessel, 9 – spherical mirror.

SERPUKHOV RICH physics

Ten years ago a new type of a phototube was proposed at the Serpukhov Institute for High Energy Physics. It has a long photocathode and allows a photon coordinates to be detected by measuring the drift time to the dynode system. The phototube, called a hodoscope photomultiplier (HPM), was used in a number of detectors. One of the most interesting applications is for the detection of Cherenkov radiation rings. The first Ring Imaging Cherenkov Counter (RICH) with an HPM was used in the 1974 experiment to observe antitritium nuclei.

The HPM has a 20 cm-long photocathode, a resistive electrode along the photocathode forming the required electrical field, a transition region, and a multiplying dynode system. The HPM is placed in a permanent magnetic field so the photoelectrons drift in crossed electric and magnetic fields. This trick substantially increases the electron path to the dynode and improves the space resolution. The position of the photoelectron emitted by a photon from the photocathode is defined by measuring the time-delay of the signal from the HPM using a time-of-flight method. The trigger signal and the signal from the HPM are used as the start and stop signals, respectively. Single photon space resolution of the HPM is 3 mm.

Recently a large aperture RICH utilizing HPMs has been constructed at Serpukhov for the focusing two-arm spectrometer used for high transverse momentum experiments. The RICH consists of a steel vessel with a

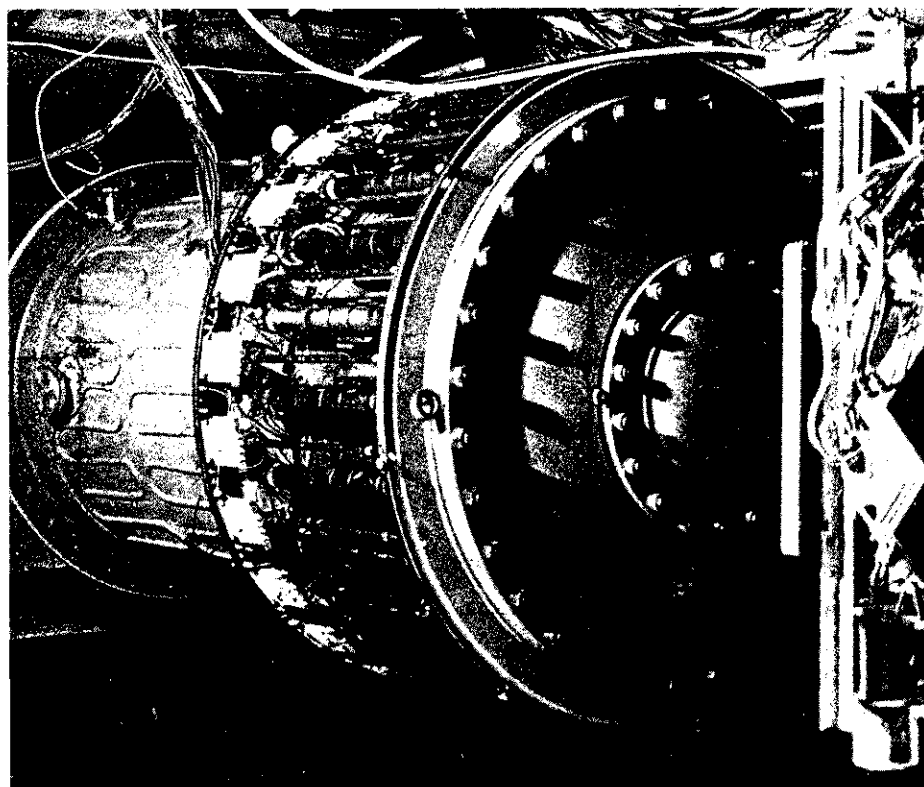
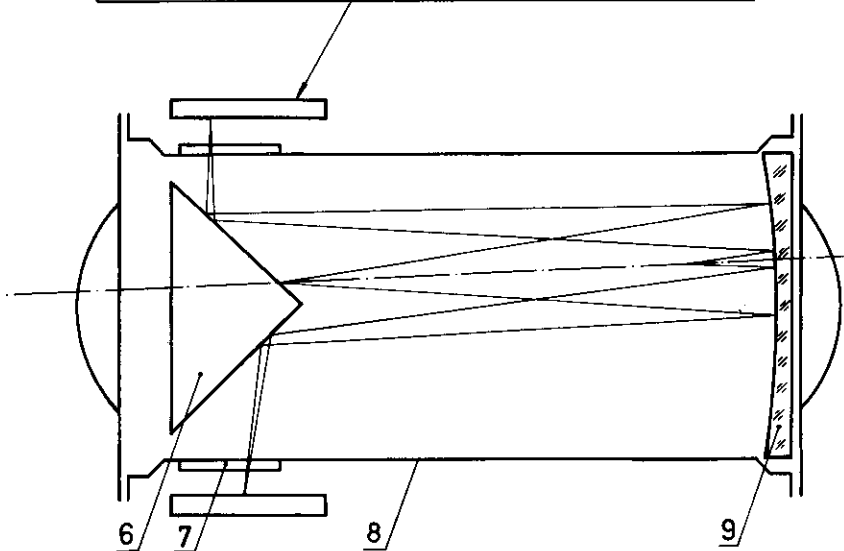
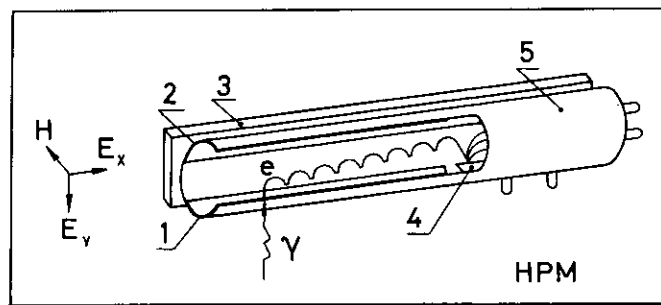

An external view of the Serpukhov RICH showing its surrounding ring of hodoscope photomultipliers.

gaseous radiator, a spherical mirror, and HPMS placed in the focal plane. A conical reflector is used to reflect the light out of the beam.

Cherenkov light emitted by a particle in the radiator is focused into a ring in the focal plane, divided into 24 sectors, where the HPMS are placed. The Cherenkov ring radius and its centre are unambiguously related to the particle velocity and the angle between its trajectory and the RICH axis. The quantities are reconstructed from the measured photon coordinates in the HPMS. Drift chambers provide independent measurements of the ring centre to improve the accuracy of the radius measurement and simplify multiparticle reconstruction procedures.

The RICH is designed to run at 10 atmospheres. Freon 12 is used as radiator with an effective length of 2 m. The diameter of the spherical mirror is 1.1 m and the focusing length is 2.5 m. The radial and angular apertures of the RICH are 0.45 m and 30 mrad, respectively. The angular range of the detected Cherenkov light is 40-100 mrad and the average number of photoelectrons is between 6 and 21. The velocity resolution allows pions, kaons and protons to be identified up to 30 GeV. For higher momenta, the RICH resolution can be increased using a longer radiator, and a gas with lower chromatic dispersion.

LOUVAIN-LA-NEUVE Fourfold energy boost

The maximum energy which can be reached by a cyclotron depends directly on the charge carried by the accelerated particles. Higher energies can thus be reached by removing more electrons from ions.

Frequently two accelerators are

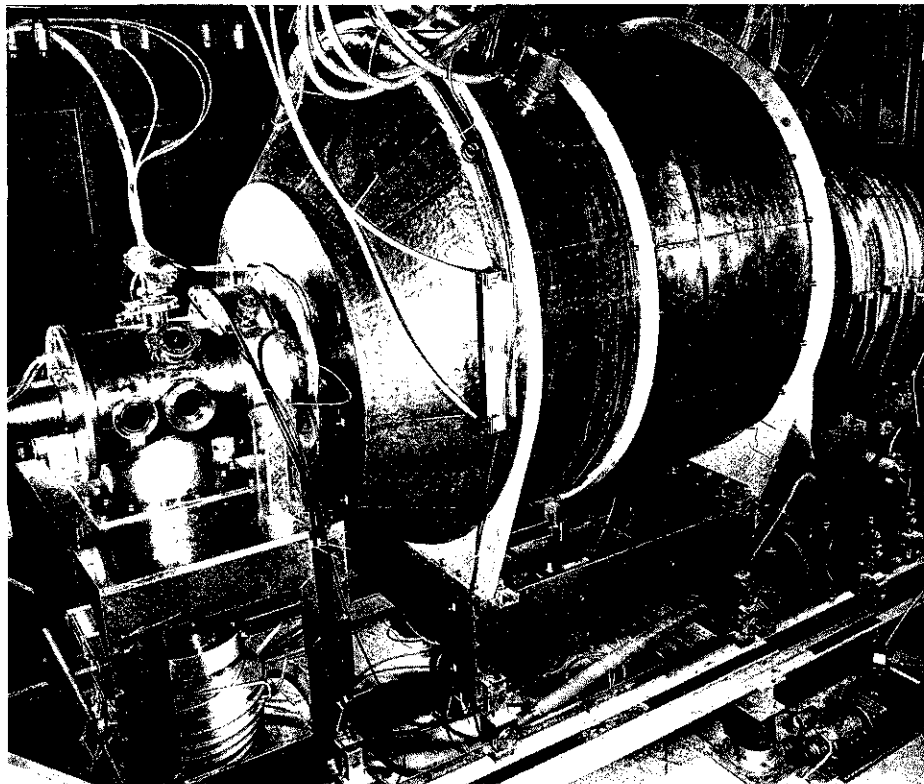

The ECREVIS ion source at Louvain-La-Neuve, Belgium, which uses techniques borrowed from fusion research. The extraction system is on the left, following the superconducting assembly.

used. Lightly charged ions, accelerated to an energy of 2 to 10 MeV/nucleon in the first machine, hit a thin target (stripper) where they lose more of their electrons. Their energy is then boosted in the final accelerator.

However a different approach to stripping is used in the ECREVIS source (Electron Cyclotron Resonance Extremely Versatile Ion Source) recently commissioned at Louvain-La-Neuve (Belgium). This type of source was developed by R. Geller's team at the CEA, Grenoble, based on techniques used in studying plasma for thermonuclear fusion.

To produce multicharged ions, a plasma composed of cold ions and extremely hot electrons is confined in a large magnetic 'bottle' — 1.2 m long and 0.35 m in diameter. The required magnetic geometry is obtained by combining a sextupole and various solenoids. Even though the required fields are quite small (1 Tesla at the wall and 3 at the coils), a superconducting system is used to minimize energy consumption.

The electrons in the plasma are selectively heated by injecting microwaves at the cyclotron frequency of the electrons in the confining magnetic field. The charge distribution of the resultant ion beams compares favourably with what could be expected from a medium-sized injector.

For CYCLONE (CYClotron de LOuvain-la-NEuve), the ECREVIS source injects completely stripped ions of carbon, nitrogen and oxygen, and of neon $9+$ and argon $16+$. Overall transmission, from source to experiment, is usually around 15 per cent. Stability, reliability and flexibility are 'remarkable'.

The heavy ion beams from the ECREVIS-CYCLONE complex are used in three studies. One looks at the behaviour of high spin nuclei, another studies the fragmentation of titanium 44 into two sodium 22 fragments, and the third investigates nuclei far from stability using the LISOL on-line isotope separator.

People and things

Felix Bloch

As reported in our October issue, Felix Bloch died on 10 September in Zurich, the town where he was born in 1905. After studying and an initial appointment in Leipzig, he left Germany in 1933, emigrating the following year to the United States, where he soon moved into a position at Stanford. On the US West Coast, he worked with Ernest Lawrence, and with Luis Alvarez in a historic first measurement of the neutron magnetic moment. During the war years, his talents were in demand elsewhere, first for the Manhattan project and then in radar research. In 1952, Bloch shared the Nobel physics prize with Edmund Purcell for pioneer work in what is now known as nuclear magnetic resonance. NMR went on to become one of the standard tools of physics and chemistry, and has now emerged as a powerful new diagnostic technique in medicine.

When CERN was being set up in the early 1950s, its founders were searching for someone of the stature and international prestige to head the fledgling international Laboratory, and in 1954 Professor Bloch became CERN's first Director-General, at the time when construction was getting under way on the present Meyrin site and plans for the first machines were being drawn up. After leaving CERN, he returned to Stanford, where he continued to take an active part in physics.

June 1955. Felix Bloch, as CERN's first Director-General, laid the foundation stone of the Laboratory. With the trowel was Max Petitpierre, the Swiss President at the time. Twenty-eight years later, another Swiss President came to CERN for a similar ceremony. See photo on page 357.

(Photo CERN 2.6.55)

On people

Fritz Gutbrod is the new spokesman of the DESY Theory Group following Tom Walsh's departure for Minnesota. Gutbrod is well known for his work on lattice gauge theories involving Monte Carlo computer calculations.

Paul Williams has been appointed Deputy Director of the Rutherford Appleton Laboratory in the UK.

A school for all climates

Summer schools play an important role in particle physics. As well as providing forums for new ideas and results, they act as meeting places for young researchers. The Advanced Studies Institute on Techniques and Concepts of High

Energy Physics, to be held from 2-13 August 1984 in St. Croix, US Virgin Islands, will be the third in a series which now seems to have become a regular feature of the particle physics calendar.

The series was started by Tom Ferbel of Rochester, with assistance from the NATO Advanced Study Institutes Programme, the US Department of Energy and National Science Foundation, Fermilab, and Rochester University. The schools make a point of mixing accelerator and detector physics with topical questions of particle physics. Although held on US territory, the institute attracts many participants from outside the US.

Next summer's scheduled speakers are: A. Astbury (on Physics of Hadronic Colliders), C. Fabjan (on Calorimetry), J. Iliopoulos (on Supersymmetric Particles), R. Peccei (on Tests and Present Status of



Fritz Gutbrod (left), new DESY theory spokesman, with fellow theorist Ahmed Ali, who has migrated to CERN for a year.

(Photo DESY)



time. This is either due to a new physics effect, as yet unexplained, or more likely, to a temporary fault in the computer system.

Gauge Theories), D. Perkins (on Searches for Exotic Objects), A. Sessler (on Current and Future Developments in Accelerators), and M. S. Turner (on Cosmology in Particle Physics).

The Institute is designed primarily for about sixty young experimentalists working in the area of high energy particle physics. Senior graduate students or recent PhD recipients interested in attending should apply directly to T. Ferbel, Department of Physics/ASI, University of Rochester, Rochester, NY 14627, USA

A Symposium entitled Recent Developments in Computing, Processor and Software Research for High Energy Physics will be held in Guanajuato, Mexico, from 8-11 May, 1984. It will cover recent developments in reconstruction

processors, lattice gauge processors, software development, beam orbit processors, etc. Further information from one of the conference secretaries: Rene Donaldson, Fermilab, PO Box 500, Batavia, ILL 60 510, USA, or Isabel Menocal, Instituto de Fisica, Apdo. Postal 20-364, 01000 Mexico, D.F.

How to grow antiprotons

Alert readers were quick to spot the mistake in the photograph published on page 247 of our September issue. While the SPS display proudly proclaimed that the goal of more than 100 inverse nanobarns of integrated luminosity for proton-antiproton collisions had been surpassed, it displayed even more proudly that the intensity of the stored proton and antiproton beams had been growing with



Celebrating the first anniversary of the Argus detector at the DESY DORIS II ring. Left to right in the foreground are Robert Hofstadter, Paul Söding (back to camera), DESY Director Volker Soergel and Gus Weber.

(Photo DESY)



Germany at CERN

The first exhibition of German enterprises
at CERN is taking place from November 29 to
December 1, 1983.

The Federal Ministry for Research and Technology regards this exhibition as an excellent opportunity to acquaint those responsible at CERN for the construction and operation of research facilities with the technical and economic capacities of a selected number of German enterprises. The exhibition is to help improve the cooperation and technology transfer between basic research and industry in their mutual interest.

On the initiative and under the auspices
of the Federal Ministry for Research and Technology



AEG

AEG-Telefunken
Anlagentechnik AG
Fachbereich Leistungselektronik
und Anlagenbau
Brunnenstraße 107a
D-1000 Berlin 65
Telephone: (030) 467-1 · Telex: 185973

Branch in Switzerland:
Elektron AG, CH-8804 Au Zh
Telephone: (01) 7830111 · Telex: 875755

Production line:

Planning and supply of plant and components for all branches of electronics.
For nuclear research in particular:
- High and low voltage switchgear
- Power electronics
- Heavy current supplies
- a. c. and d. c. drives
- Static and dynamic reactive power compensation
- Elements for the evaluation of analogue and digital signals
- Mechanical assemblies
- Workshop services (electr./mech.)

Products exhibited:

Power electronics components for magnet supplies and reactive power compensation.
- Rectifier assemblies for heavy current
- Rectifier assemblies for high voltage
- Digital main reference-value emitter
- User oriented digital elements



AUERGESELLSCHAFT GMBH
Thiemannstraße 1-11
P. O. Box 40 04 40
D-1000 Berlin 44 (West)

Telephone: (030) 6891-0 · Fax: (030) 6991-558
Telex: 184915 auer d · Cables: auerprod berlin

Represented in Switzerland by:
Schönholzer AG
Schwarztorstrasse 31
CH-3000 Bern 14
Telephone: 031 259651
Telex: 32889

Production line:

Products for Safety at Work
Permanent Instruments: permanent instruments and installations for indication, detection, monitoring, recording and warning of combustible or toxic gas/vapor in air concentrations · instruments for gas analysis and control.
Air Purification: high efficiency particulate matter filters, particle filters, activated charcoal filters for application in industry, nuclear plants and hospitals; filters for air raid shelters.
Medical Technics: appliances for balneological therapy.
Incandescent Gas Mantles: for street lantern, camping, rail road signal, buoy and green house lighting.

Products exhibited:

Respiratory protective devices
Protective clothing
Portable and permanent instruments for detection, indication, and warning of gas/vapor in air concentrations



Germany at CERN

RÖHR

TECHNIK IN BLEI

BLEIWERK GEBR. RÖHR KG
Bruchfeld 52
D-4150 Krefeld 12 (Linn)
Telephone: (0 21 51) 59 02 33-35
Telex: 853 823

General representative (CH):
Jakob Scherrer Söhne AG
Mendstr. 7
8059 Zürich 2
Tel.: (01) 202 79 80
Telex: 58700

Production line:

Rolled and extruded products made of lead and lead alloys, especially lead sheet and plate from 0,2 to 200 mm thick, up to 3,20 m wide in coils up to 300 m long. Special lead sections, lead wire and lead pipes up to a width or outside diameter of 300 mm. Lead sheets bonded to supporting plates (composite material)
Nuclear engineering:
- Lead bricks according to DIN 25407 and euratom
- Lead containers
- Lead linings and other lead screens

- Precision lead components — stamped, pressed deep drawn or die-cast
- Lead granules

Products exhibited:

For the new accelerator LEP:
- Dipole vacuum chambers in aluminium with lead cladding:
- Extruded lead shieldings for these chambers
- Special lead sections
- Lead bricks
- Lead containers
- Lead safes
- Lead shielding for pipework



BRAND

RUDOLF BRAND GMBH + CO
Laboratory and Vacuum Equipment
P. O. Box 310
Otto-Schott-Straße 25
D-6980 Wertheim
Tel. (093 42) 808-0 Telex: 689 110

Production line:

Vacuum equipment such as:
- rotary and diaphragm pumps
- small-flange components
- valves and gauges
- pumping units
Volume measuring instruments such as:
- dispensers, dilutors, pipettors, titrators
- volumetric glassware
Plastic labware — disposables made of glass and plastic — blood testing apparatus

Products exhibited:

rotary and diaphragm pumps
pumping units
small-flange components
valves and gauges
dispensers, pipettors, titrator



BUSAK + LUYKEN GMBH & CO
Postfach 800206
D-7000 Stuttgart 80
Telephone: (07 11) 78 64-0
Telex: 725 511-0
Telefax: 07 11/78 64-425

Production line:

Sealing elements for different applications in nuclear and chemical industries, in instrument and machine manufacture, in hydraulics, pneumatics, aircraft and space industries. Seals for high and low pressure systems, for high and low temperature applications, for all gaseous and liquid fluids. Seals available in wide range of combinations of materials and designs in various compounds e. g. nitrile, Viton®, Kalrez®, Tefzel, Vespel®, silicone, ethylene propylene, neoprene, Turcon®, PTFE.

Products exhibited:

Typical samples of our production line, e. g.:
- O-Rings in various compounds; Metal-O-Rings
- Turcon®, Glyd®-Rings, Double-Delta®-Seals, Variseals®
- Mechanical Seals, Grafseal®, Flexible Graphite
- Cefil'Air (air or fluid activated flexible seal)



Cable Works Friedrich C. Ehlers
Gotenstraße 10
D-2000 Hamburg 1
West-Germany
Telephone: (0 40) 23 71 50
Telex: 2 162 802 kwe d

Manufacturing range:

Special fire and radiation resistant, flame retardant, halogene and sulphur free (FRNC) PYRO-ELODUR Safety Cables as:
- power cables up to 20 kV,
- control cables,
- instrumentation cables and thermocouples compensating leads,
- telecommunication cables
- safety cables to customers specifications — »taylor made«
Power Cables up to 30 kV:
PVC, PE, XLPE insulated, with or without concentric conductor, with or without armour, with or without lead sheathing

Off-Shore/Ship-Wiring/Marine/Heavy Duty Cables in standard execution and as PYRO-ELODUR Safety Cables
Instrumentation and Control Cables. Thermocouples Compensating Leads for measuring and control systems
Telecommunication Cables both for indoor and outdoor use
Our cables are made to all World known Standards and approved by all most important Classification Societies.

Products exhibited:

Samples of PYRO-ELODUR Safety Cables. Our exposition is extended by regular Video and Slides presentations on these PYRO-ELODUR Safety Cables in English and in French.



Germany at CERN

DORNIER

DORNIER SYSTEM GMBH
Postfach 1360
D-7990 Friedrichshafen 1
Telephone: (07545) 81
Telex: 734209-0 do d

Program of supplies and services

Development and manufacturing of complete systems
Material technology: Interface physics · Powder metallurgy · Interface and thin film analytics · Coating technology · Ceramics development
Nuclear technology: Reliability analyses · Process development · Process safety engineering
Hydrogen technology: High-temperature · Electrolysis
Energy technology: Systems technology · Thermodynamics · Aerodynamics · Thermal analyses
Cryotechnology · 3D Navier · Stokes equation solution which is precise with respect to time
Manufacture: Manufacture of complex mech./elektron. systems · Fibre composite components · E.B. welding · Simulation and

manipulation systems · Structures for highly dynamic motions · Complex strength calculation · Gas ultra-centrifuge
Further activities: Electronics · Environmental technology · Information and communications technology · Transport technology · Space technology
Products exhibited: Model of the muon chamber of the CERN experiment UA 1 · Niobium cavity · Coating technology-coating examples · Material technology-fibre composite material for wave guides

HEINZINGER

HEINZINGER
Control & Measuring Instrumente
Happinger Straße 71
D-8200 Rosenheim
Telephone: (08031) 641 41
Telex: 525 777 hemes d

Production line:

Stabilized DC-Power supplies from modules up to 500 kW.
Class 10-4 till 10-6

for:

- laboratory, magnets, supraconductors,
- xenon-lamp, multiplier, laser, capacitor-charging,
- static lenses.

HV-System-DVM up to 132 kV DC accuracy + — 1.10-4 + — 1 digit,
TK: 10 ppm/K
HV-Isolating-Transformers
HV-Connectors and cables up to 300 kV =

INTERATOM

INTERATOM
Internationale Atomreaktorbau GmbH
Friedrich-Ebert-Straße
D-5060 Bergisch-Gladbach 1
Telephone: (02204) 48-0
Telex: 8878 457 iagl d · 8878 492 iagl d
Telecopierer: (02204) 48-30 45

Manufacturing and Services:

components for nuclear power plants
components for uranium-enrichment plants
nuclear and process related test facilities
accelerator and controlled fusion components
piping systems (aluminium, stainless steel, copper)
heavy aluminium structures by welding
high-temperature brazing
electron-beam welding
TIG, MIG, Plasma and Plasma-MIG-welding,
orbital-welding
CNC-drilling and -turning
In addition, INTERATOM offers supporting engineering services
for the above mentioned items.

Products exhibited:

LEP-cavity 350 MHz (model)
dipole- and quadrupole-vacuum chambers (model)
5-cell superconducting niobium structures
vacuum-brazed and electron-beam welded samples
plasma-MIG welded samples

KRUPP

Fried. Krupp GmbH
Altendorfer Straße 103
P. O. Box 102252
D-4300 Essen 1
Telephone: (0201) 188-1
Telex: 857 385 fkes d

Production line:

Plantmaking
Mechanical Engineering
Trading and Services
Steelmaking
Shipbuilding

Products exhibited:

Vacuum and high-vacuum engineering
- Textor high-vacuum vessel for nuclear fusion
- Textor nuclear research chamber
- Asdex high-vacuum vessel
- Jet-Limiter

Magnet Engineering
- Magnetic materials
- Magnet systems for use in nuclear physics and basic research
- Measuring instruments for magnet engineering
Process Data Systems
- Synchronous duplex computers
- Color display systems
- Executive control systems
- Application packages
Noise and Vibration Measurements
Special Alloys



Germany at CERN

LYNENWERK

LYNENWERK GmbH & Co., KG
POB 1240
Dürener Straße
D-5180 Eschweiler
Telephone: (024 03) 75-1
Telex: 832 142

Production line:

For automation and remote control:

- computer cables
- control cables
- signalling cables
- measuring cables
- cables for thermocouple

For hazardous areas:

- flame retardant cables
no halogen
low smoke emission
low emission of toxic and corrosive gas
highly resistant to nuclear irradiation
- fire resistant cables
circuit integrity for more than three hours

Furthermore:

- heavy duty TRS cables
 - cables for lifting gear
 - installation cables
 - power cables for low and medium voltage
 - cables to customer's specifications
- displayed products:
- same as above



MANNESMANN DEMAG Fördertechnik

Mannesmann Demag
Fördertechnik
D-5802 Wetter (Ruhr) 1
Telephone: (02335) 821
Telex: 823231

Production line:

Components, installations and systems providing solutions to materials handling problems
Drives, gear motors, control and closed loop control units
Travel carriages, mechanical and electrical components
Electric chain hoists and electric wire rope hoists for capacities up to 80,000 kg,
open winch crabs up to 125,000 kg
Work station jibs and cranes, overhead travelling cranes, suspension cranes
Suspension monorail systems
Roller, chain and belt conveyors
Automatic guided vehicles

Warehouse and goods distribution systems

Airport equipment

Products exhibited:

- DC motor
- RS wheel block, compact travel and drive unit for heavy loads
- DSB electric suspension monorail for overhead materials handling systems

MESSER GRIESHEIM



Messer Griesheim GmbH
Hanauer Landstraße 330
D-6000 Frankfurt 1
Telephone: (06 11) 40 19-1
Telex: 417 138 mgfh d

Schweisstechnik AG
Langwiesenstraße 12
CH-8108 Dällikon/Zürich
Schweiz
Telephone: (004 11) 84427 11
Telex: 53053 sagre ch

Sales and exhibition program

industrial and speciality gases, gaseous and liquid
transport and storage vessels, piping and other equipment for cryogenic application
gas purifying and drying units
pressure controllers and supply equipment for industrial and speciality gases

gas welding equipment
flame cutting machinery and guiding machines for cutting processes
gas-shielded welding equipment for mig/mag, tig, plasma arc processes
pipewelding systems

plasma arc and laser welding systems
measuring and monitoring equipment
eb techniques for welding systems



Münchener Apparatebau
Kimmel GmbH
Hans-Stießberger-Straße 2
D-8013 Haar
Telephone: (089) 462031
Telex: 523092

Production line:

Health physics instruments and a complete range of components as electronics and radiation detectors, for system completions
- portable and installed dose and dose rate
- mobile and installed contamination monitors
- systems for checking and handling of radioactive waste
- particulate in air and gas monitors, esp. TRITIUM-monitors
- computerized beta particulate monitor with tape filter system
- computerized radiation measuring carts (intervention carts)
- low level measuring systems and airborne particulate samplers

- environmental monitoring systems
- standard nuclear electronics and MICRO-PROCESSOR system & software
- wide range of detectors for X-ray, Alpha, Beta, Gamma & Neutron radiation

Products exhibited:

computerized beta particulate monitor (tape filter systems), model AMS 9. X
precision dose and dose rate meter (gamma & X-ray), model MAB 605
microprocessor based neutron dose rate meter, model REM 909
tritium and noble gas monitor, model TMH 2



Germany at CERN

NTG Nukleartechnik

NTG NUKLEARTECHNIK
GmbH & CO KG
Am Spielacker
D-6460 Gelnhausen 2
Telephone: (06051) 6241/6251
Telex: 4 184320 ntg d

Program of supplies and services

Plans · Calculates · Designs · Develops · Manufactures in the fields of:
Nuclear Technique · Nuclear Physics · Beam Line Systems · Power Station Technology · Reprocessing · Environmental Protection · UHV-Technique · Tritium Technology · Fusion Technique

For example:

Our Standard Delivery Program for Beamline-Systems:

Complete Beam Line and Beam Diagnostic Systems · Emittance Measurement Device with complete Electronic and Microprocessor equipment (hardware and software) · Magnet Chambers · Ultra High and High Vacuum Chambers and Tanks of every Geometry and

Size · Universal Precision High Vacuum Feedthrough · Compressed Air Actuated High Vacuum Feedthrough · Slit Jaws for Beam Size Limitation, Beam Analysis and Energy Definition (cooled and uncooled version) · Coaxial Faraday Cups · Faraday Cups (provided for up to 25 kW beam power) · Beam Profile Measurement Systems · Variable Segmented Aperture · Beam Stopper combined with Beam Position Measurement · Rotating Wire Scanner · Beam Transformer · Capacitive Pick-Up · Linear and Rotating Feedthrough · Complete Electronic Control Systems and Plants · Standard UHV and HV Components (CF-flanges, bellows, etc.)

Products exhibited:

Beam line components · Ion-getter-pump · Fast breeder fuel element (dummy)



odu-kontakt gmbh & co kg
elektronik — vertrieb
Herzog-Friedrich-Straße 3
Postfach 269
D-8260 Mühldorf/Inn
Telephone: (08631) 120 14-1 20 17
Telex: 56 735

Production line:

single pole contacts
circular connectors
socket and pin strips for printed circuit boards
FLAKAFIX tape cable sets

Products exhibited:

Reactor implementations
Socket connectors for reactor implementations for the cold side
for the hot side



Reaktorwartungsdienst & Apparatebau GmbH
in Jülich
Eleonorenstraße 1
D-5170 Jülich
Telephone: (024 61) 2992
Telex: 833559 rewa d

Production program

UHV technique
- UHV installations
- UHV manipulators
- UHV chambers
- UHV metal bellows
Accelerator technique
- components for beam diagnostic
- lines of acceleration
- emittance measuring device
- special components

Cryotechnique
- evaporation cryostat
- transfer pipes

Products exhibited:

High-performance beam diagnostic-systems
UHV manipulators
Metal bellows
Measuring device for health protection
UHV connecting technique



F. X. STÖHR GmbH & Co.
Armaturenwerk KG
Provinstraße 22
Postfach 11 18 69
D-8900 Augsburg
Telephone: (08 21) 553094
Telex: 533528 stoeh d

Production line:

full lift-, proportional safety valves
pressure relief safety valves; high vacuum tight non-return valves, inspection glasses, couplers
needle valves, quick acting vacuum valves
throttle type valves, cryogenic valves
pneumatic valves, motor valves
pressure reducing valves
pressure reducing units
cryogenic transfer lines
low temperature equipment

Products exhibited:

pressure reducing valves, safety valves
non-return valves, inspection glasses
on-off valves, coupler for vacuum transfer line
cryogenic valves, control valves
pneumatic valves
cryostat, made of synthetic material



Germany at CERN



DR. B. STRUCK



Dr. Bernd Struck
Turfstraße 163
D-2000 Tangstedt
Tel. (041 09) 6252
Telex 2180715 tegs

Modutec
Am Osdorfer Born 30
D-2000 Hamburg 53
Tel. (040) 8030 12-15
Telex: 2163678

Production line:
CAMAC products
NIM products
FASTBUS products
Physical Trigger Systems
Track processors
VME products
Microprocessor developments Z 80, 8086 based (user specific)
Bloodgasanalyser, gradientoven, animal feeding processors
Oceanographic research - IEEE 488 products
relative navigationsystems
Militaric developments

Products exhibited:
FASTBUS products
Crate, FIORI, BUS-Monitor, Display Unit, KLUGE Cards
IEEE 488-products
NIM products
VME products

Modutec
Products exhibited:
19" cabinets and racks
CAMAC and NIM-crates
FASTBUS-crates and card-frames for EUROCARDS
Modules and cassetts for all systems
Airconditioners and blower-systems
Power supplies for CAMAC, NIM and card-frames



Turbo-Werk
Messtechnik GmbH
Gremberger Straße 151
D-5000 Köln 91
Tel. (0221) 838031
Telex: 8873264 turb d

Represented in Switzerland by:
Dipl.-Ing.
F. Baumgartner
Schiffände 7
Ch-8703 Erlenbach

Production line:
Variable Area Flowmeters (Float Type In Glass And Metal)
Flapper Type Flowmeters And Indicators
Target Type Flowmeters And Monitors
By - Pass Flowmeters
Magnetic - Inductive Flowmeters
Magnetic - Inductive Flowsensors
Level Indicators And Controllers

Products exhibited:
Variable Area Flowmeters (Float Type In Glass And Metal)
Flapper Type Flowmeter And Indicators
Target Type Flowmeter
Magnetic - Inductive Flowmeter
Magnetic - Inductive Flowsensor

VOITH

J.M. Voith GmbH
Postfach 1940
D-7920 Heidenheim
Telephone: 07321-370
Telex: 7147999 vh d
Cable address: Voithwerk Heidenheimbrenz
Telefax: 07321-373000

Production program:
Machinery and equipment for the production of paper
Water turbines
Hydraulic equipment, large valves, hydraulic steel structure engineering
Voith-Schneider Propellers and other special drives
Pumps
Special designs for research and industrial systems
Hydrodynamic converters, couplings, brakes and gear units
Heavy-duty gear units, industrial gear units
Hydrostatic pumps and components
Aerodynamic engineering: air supply and ventilation systems, cooling systems, wind tunnels, tunnel ventilation systems

Voith-Hirth radial spur serrations
Frequency converters
Electronic controls
Heavy-duty cardan shafts
Machine tools
Industrial manufacture: casting, welding, machining for farmed-out work

Products exhibited:
Model of coupling
Model of a reflecting telescope
Voith-Hirth radial spur serration
IPH pump
Model of a transverse-flow fan



Carl Zeiss
Carl-Zeiss-Straße
D-7082 Oberkochen
P.O. Box 1369/1380
Tel. (07364) 20-1
Telex: 71375155

Branch in Switzerland:
Carl Zeiss Zürich AG
Grubenstrasse 54
CH-8045 Zürich
Tel. (01) 4612300
Telex: 813277

Production line:
Microscopes
Image analysis and photometric systems
Electron microscopes
Medical instruments, ophthalmological instruments
Instruments for industrial metrology
Geodetic instruments
Photogrammetric instruments
Camera and special lenses
Planetaria and astronomical instruments
Binoculars, loupes, spectacle lenses, sunglasses
Special assignments for research and science

Products exhibited:
Microscopes
Geodetic instruments
Magnifying visual aids

Organization of the exhibition: Kienbaum International Promotion GmbH
D-5270 Gummersbach and Partner Mr. W. Esser, Mrs. Dr. G. Heppner

The Max-Planck-Institut für Physik und Astrophysik, Munich, is offering three positions for young

Ph. D. Physicists in Elementary Particle Physics.

We are looking for experimental physicists with experience in high energy particle physics to participate in

- neutrino experiments with BEBC (CERN) and with the 15-foot bubble chamber (Fermilab),
- muon experiments with a vertex detector (streamer chamber) and a forward spectrometer at CERN (NA9) and at Fermilab,
- a hadron experiment to study the production of large transverse momentum prompt photons with a calorimeter detector (NA24) at the CERN SPS.

These appointments will normally be for three years with a possible extension.

Applications (including curriculum vitae, list of publications and the names of two referees) should be sent as soon as possible to:

Prof. N. Schmitz
Max-Planck-Institut
für Physik und Astrophysik
Föhringer Ring 6
D-8000 München 40, West Germany

Research Associates: High Energy Experimental Physics

SUNY at Stony Brook is organizing an experiment at the DO area of Fermilab to study $p\bar{p}$ collisions at 2 TeV. The experiment will stress high resolution studies of leptons (e and μ) and photons, as well as good hadron calorimetry. Positions are available for responsibilities in all phases of the hardware and software development. Salary and terms of appointment are negotiable and will depend on length of previous experience. Interested applicants should send vita, and have at least two letters of reference sent to:

**Professor M. Marx, Physics
Department, SUNY Stony Brook,
Stony Brook, NY 11794.**

SUNY Stony Brook is an equal opportunity/
affirmative action employer.

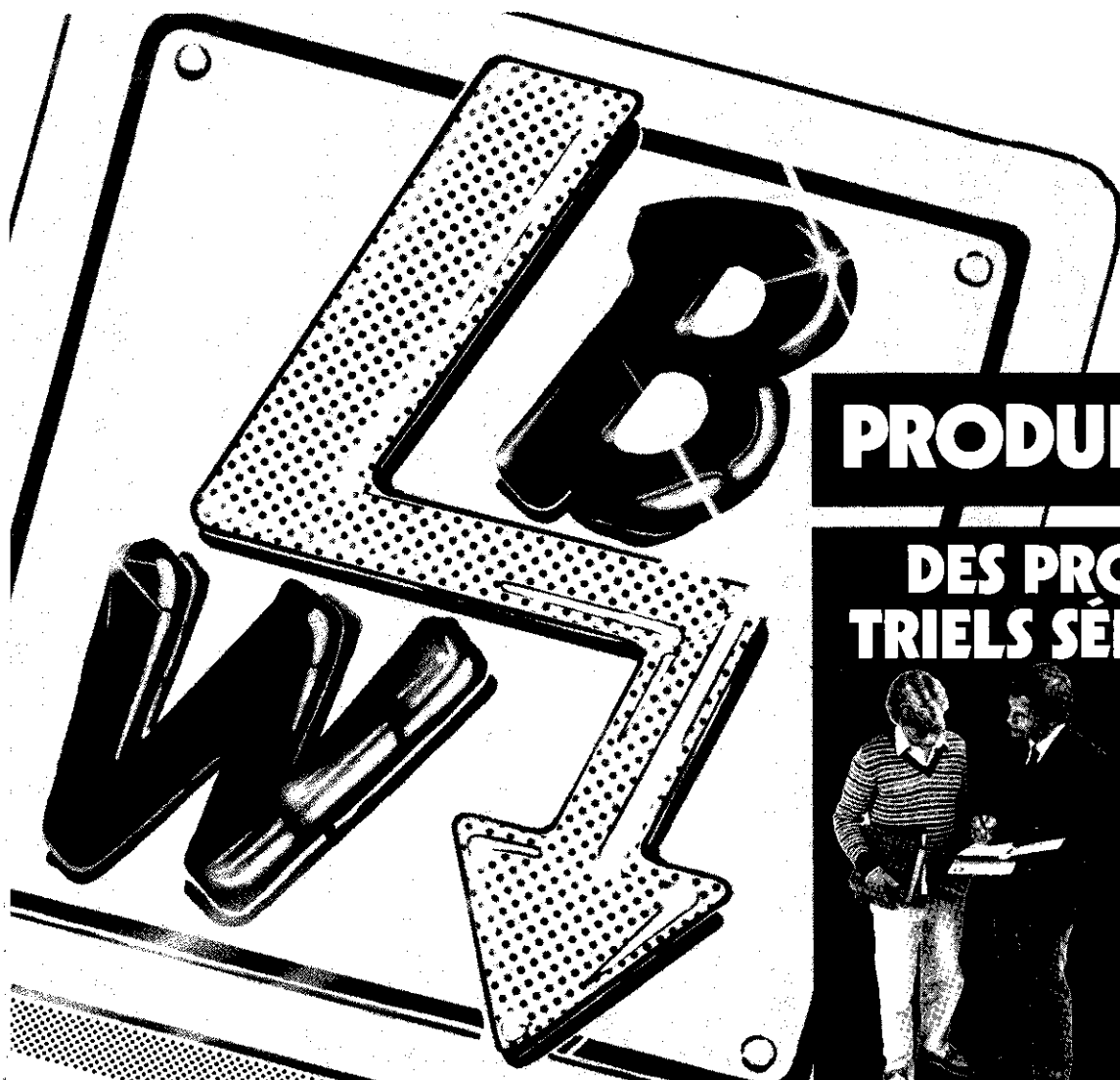

PRODUITS INDUST

DES PRODUITS INDUS- TRIELS SÉLECTIONNÉS –

DES CONSEILS JUDICIEUX



Division Produits industriels:

- Constructions de supports de câbles
- Technique de mesure
- Protection contre la chaleur
- Surveillance de l'énergie
- Sécurité
- Technique à courant fort

UNIVERSITY of BASLE

The nuclear and particle physics group of the Institute for Physics has an opening for a

Research Associate

in its experiments at CERN (LEAR).

Applicants should have some postdoctoral experience in experimental intermediate or high energy physics. Candidates are expected to be capable to take over responsibilities for the data acquisition system (VAX 750). Appointment is for a maximum of 6 years.

Applications should be sent to:

Prof. Dr. G. Backenstoss
Institut für Physik
Klingelbergstr. 82
CH-4056 BASEL



Postdoctoral Positions in EXPERIMENTAL HIGH ENERGY PHYSICS

The Enrico Fermi Institute at the University of Chicago has immediate openings for Research Associates in several of its high energy physics experiments. These include approved experiments at the Fermilab Tevatron on μ -pair production, CP violation, and neutrino interactions as well as with the Fermilab $\bar{p}p$ collider (CDF) and at LEP with the OPAL experiment. In addition there is a campus based experiment on magnetic monopoles. In some cases there is opportunity for involvement in both a running experiment and a longer term project.

We are situated an hour from Fermilab and have excellent technical resources.

Applicants should be versatile and have completed a Ph.D. or its equivalent. Appointments are normally for 2 years but extensions are possible. The University of Chicago is an equal opportunity/affirmative action employer.

Replies, including a resume and the names of three referees should be sent to: Professor J. E. Pilcher, Enrico Fermi Institute, 5640 South Ellis Avenue, Chicago, IL 60637.

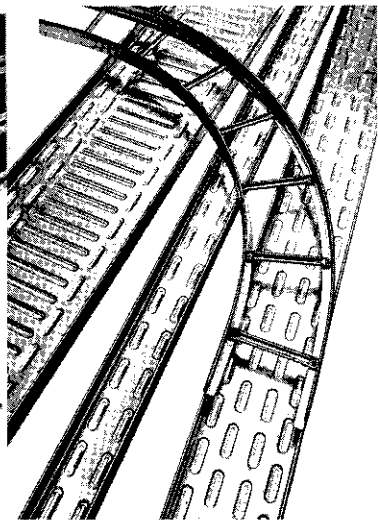
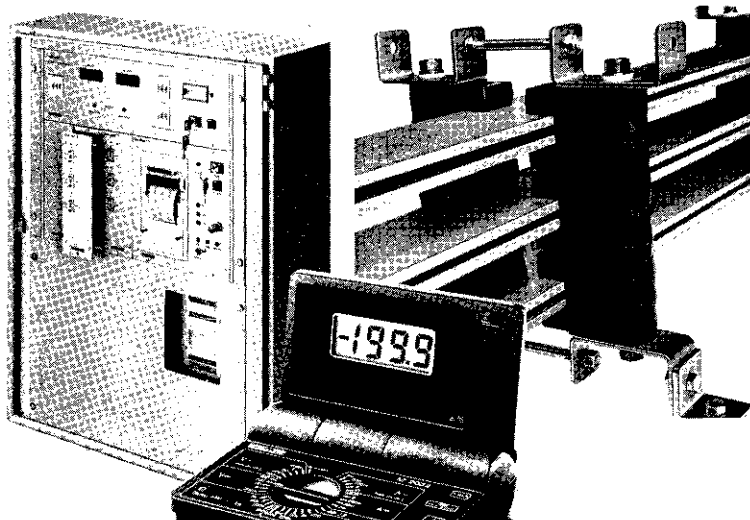

Six vastes assortiments de Bruno Winterhalter AG, clairement délimités pour le spécialiste, avec le minimum de types et d'exécutions possible. Instruments, appareils, installations, composants et matériels de fabricants réputés soigneusement sélectionnés. Pas de produits bon marché, mais des produits de haute qualité à des prix calculés au plus juste.

Division Produits industriels - conseils par des spécialistes expérimentés de Bruno Winterhalter AG. Des spécialistes qui connaissent non seulement leurs produits, mais également vos problèmes et exigences. Des spécialistes et des partenaires qui parlent la même langue. Et en plus, une documentation claire et compréhensible toujours à jour.

Et en deux langues.



Bruno Winterhalter AG
Division Produits industriels

Oberwiesenstrasse 4
Téléphone 01 - 830 12 51

8304 Wallisellen
Télex 53 132

Autre filiale:

Grossmatt
6014 Littau-LU
Tél. 041-55 74 74
Télex 78 140

Siège social:

Werkstrasse 5
9006 St. Gallen
Tél. 071-24 94 17
Télex 77 303

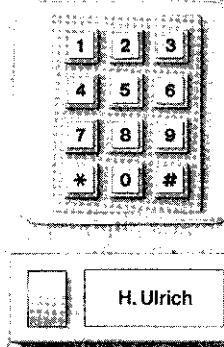

UNE TECHNOLOGIE A LA HAUTEUR DES BESOINS EXIGEANTS

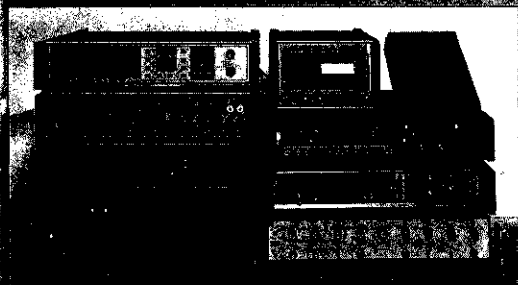

RACAL-DANA dispose d'une large gamme d'appareils de mesure, présente dans tous les domaines de l'industrie.

Son commutateur de voies programmable permet de réaliser des systèmes évolutifs de mesure en BUS-IEEE, pour l'acquisition et le traitement de signaux allant du continu aux hyperfréquences.

Les chaînes de mesure ainsi réalisées, faisant appel aux technologies les plus avancées en instrumentation, peuvent assister dans les meilleures conditions les réalisations technologiques les plus ambitieuses.

RACAL-DANA la maîtrise du signal

18, avenue Dutartre - Parly II
78150 LE CHESNAY
Tél. : (3) 955.88.88 - Télex : 697215 F

AGENCE RACAL DANA
RHONE-ALPES/CENTRE
35, rue du Tonkin 69100 VILLEURBANNE
Tél. : (7) 889.77.77
M. BIJONNEAU Représentant exclusif pour le CERN

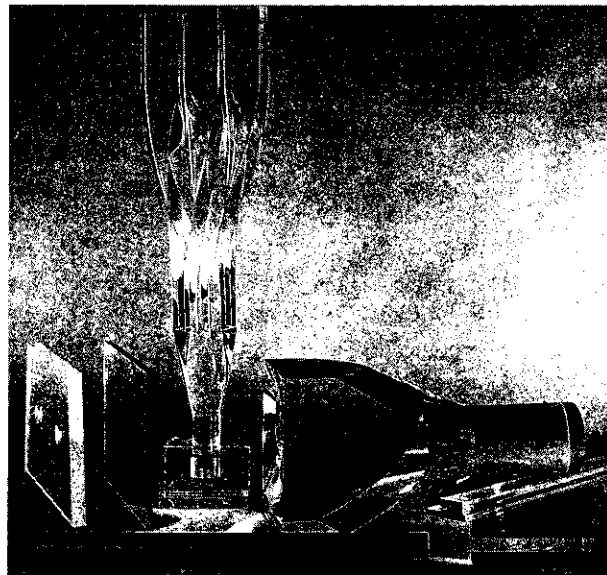

POLIVAR S.p.A.

Via Naro, 72 P.O. Box 111
00040-POMEZIA (Roma)
Telefono 06/9121061 Telex 611227 PLVI

Product line

Cast acrylic sheets, bars, blocks, scintillators,
light guides

Advertisements in CERN COURIER

Format A4

Monthly publication

All advertisements are published in both English and French editions. Second language versions accepted without extra charge.

Space (page)	Actual size (mm) width by height	Cost per insertion (Swiss Francs)			
		1 insertion	3 insertions	5 insertions	10 insertions
1/1	185 x 265	1550	1500	1450	1350
1/2	185 x 130	850	820	800	750
1/4	90 x 130	480	450	430	410

Supplement for:

— each additional colour 1500 SwF

— Covers:

Cover 3 (one colour) 1850 SwF

Cover 4 (one colour) 2450 SwF

Publication date

1st of month of cover date:

Closing date for

positive films and copy

1st of month preceding cover date

The cost of making films and of translation for advertisements are charged in addition.

Screen (offset)

60 or 54 Swiss (150 English)

Advertisements cancelled after 1st of month preceding cover date will be invoiced.

Advertising space is limited to 50% of contents and insertions are selected on a strict first-come first-served basis. These rates are effective for the year 1983.

All enquiries to:

Micheline FALCIOLA / CERN COURIER - CERN
CH-1211 Geneva 23 Switzerland
Tel. (022) 83 41 03 Telex 2 36 98

SOFT X-RAY STREAK CAMERA 10eV TO 10KeV SPATIAL DYNAMIC RESOLUTION: 20 LINE PAIR/MM*

*Demonstrated in tests
at Los Alamos National
Laboratories

DEMOUNTABLE PHOTOCATHODE

Photocathode can be
replaced in minutes while
camera remains mounted
on vacuum chamber.

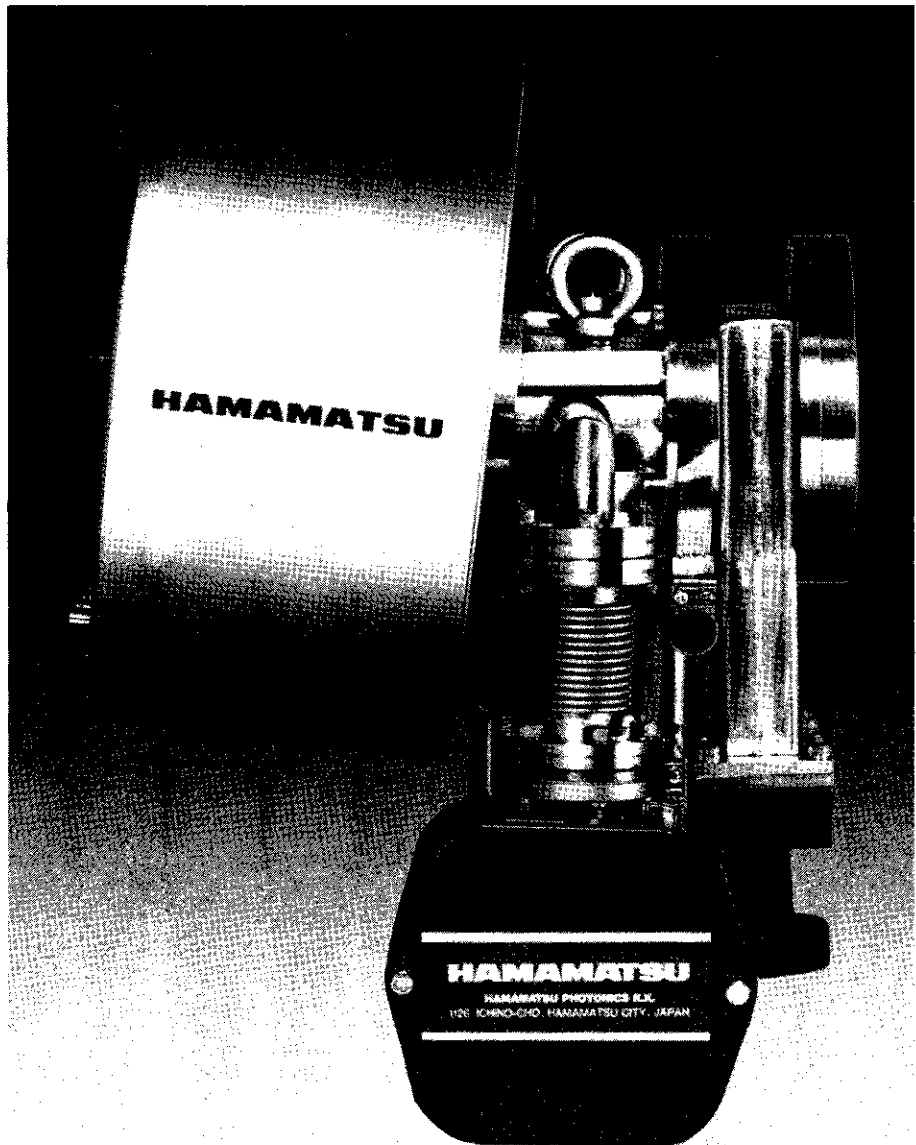
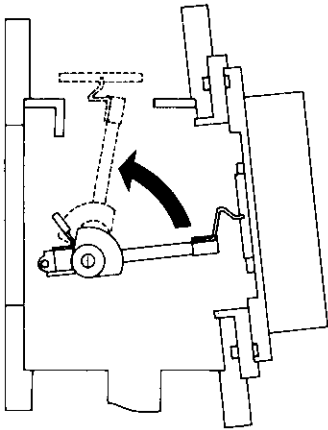

**IMMEDIATE
DEMONSTRATION
AND DELIVERY**

CALL OR WRITE FOR INFORMATION

HAMAMATSU

HAMAMATSU CORPORATION • 420 SOUTH AVENUE • MIDDLESEX, NEW JERSEY 08846 • PHONE (201) 469-6640
International Offices in Major Countries of Europe and Asia.

Hamamatsu Photonics K.K., 1126 Ichino-cho, Hamamatsu, Japan, 0534/34-3311 • Hamamatsu TV Europa GmbH, Postfach 1140, D-8031 Seefeld 1, W. Germany, 08152/7705

COMMERCIAL URANIUM. IT'S MORE THAN JUST ANOTHER METAL.



Twice as dense as lead, increasingly competitive in price, and readily available—BNFL commercial uranium could be just the other metal you've been looking for.

Currently in use for a wide range of radiological shielding and non-destructive testing applications, balance weights for aircraft, colouring

compounds for glass and ceramics and as a constituent of catalysts for the gas industry, BNFL commercial uranium is demonstrably a versatile material of great potential value to industry.

For thirty years BNFL has been fabricating commercial uranium—casting, machining, rolling, forging, extruding.

For further information write to:-
The Commercial Manager,
Misc. Products Business Centre,
Room C24,
British Nuclear Fuels Limited,
Risley, Warrington WA3 6AS

BNFL

CAMAC 750 - 1000W SWITCHING POWER SUPPLY

Now you can remove your
500W power supply

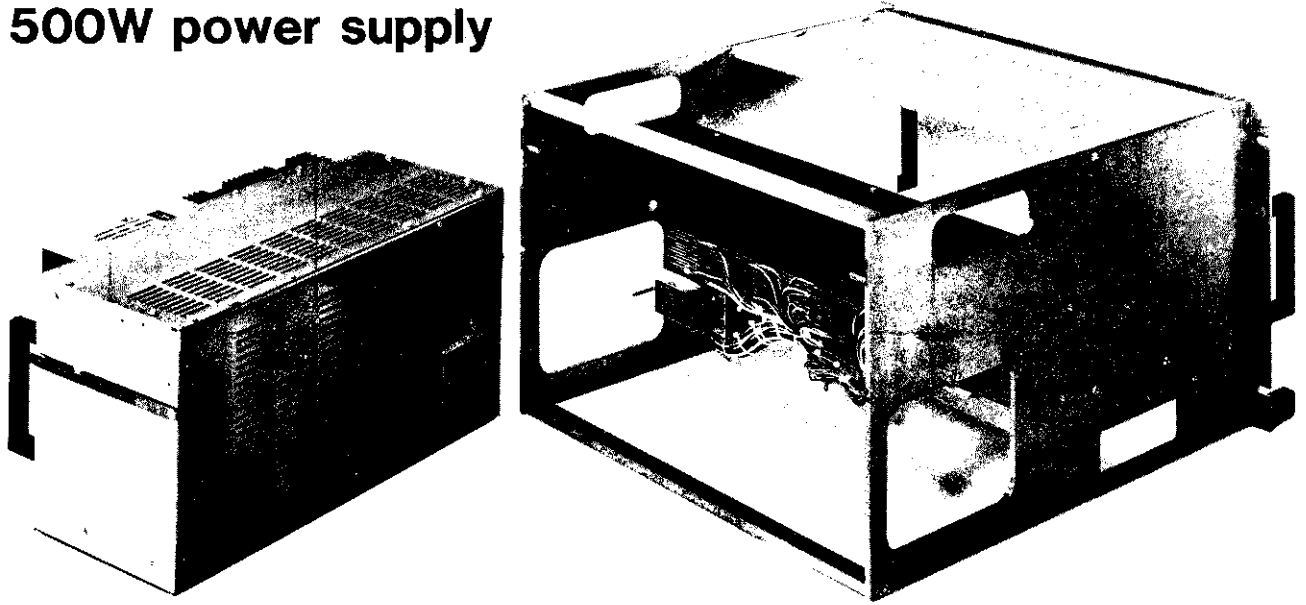

And plug in 750 - 1000W of switching regulated power
with reduced heat dissipation

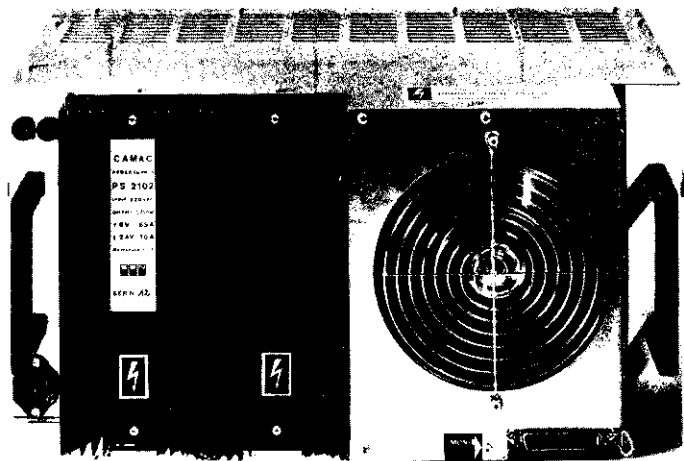

SPECIFICATIONS:

DC Outputs

+6V (+5.2V) 65A
-6V (-5.2V) 65A
+24V 10A
-24V 10A

Power Requirements

220 VAC $\pm 10\%$
at 50Hz

- * Adjustable 6V and 24V Outputs
- * Stabilized and Meter Monitored
- * PARD 50 mVpp
- * Hold Time: 10 ms with Power Failure Signal
- * All Outputs Protected Against Short-circuit by Means of Trip-off Circuit
- * Thermal Switch for Overheating Protection
- * Now in Final Stage of CERN Compliance Tests

SEN ELECTRONICS S.A.



Avenue Ernest-Pictet 31 ; Tel. (022) 44 29 40 - Tlx 23 359ch - CH-1211 GENÈVE 13 ELECTRONIQUE

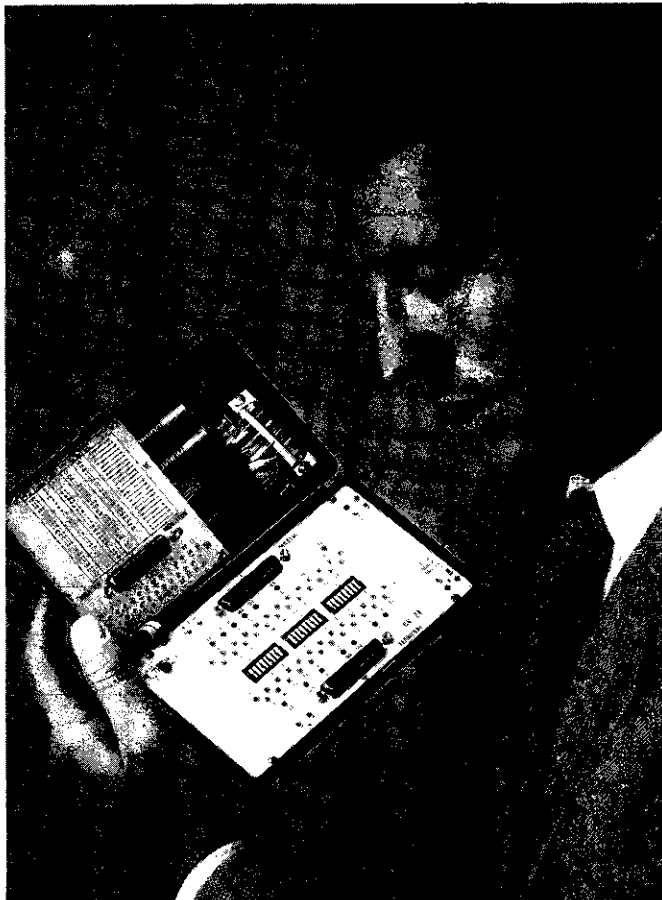

The DV-24 grabs onto an interface direct

The most important task for any data service technician troubleshooting and analyzing faults is checking functions at the V.24/V.28 Interface.

Now the economical, battery operated DV-24 Interface Tester is available. Even semi-skilled technicians can easily perform error diagnoses.

A DV-24 permits you to:

- ★ monitor the interface circuits while actually carrying traffic;
- ★ watch LED's showing the signals on the 14 most important control, indication, and timing circuits;
- ★ manually simulate interface signals;
- ★ monitor individual circuits by pulse memory having pos. and neg. trigger facilities;
- ★ set-up and disconnect data circuits manually;
- ★ separate each of the 25 interface circuits (except for ground conductors) by a switch;

★ connect additional data test sets without problems.

Your universal tool for working on teleprocessing equipment. The DV-24 is small, light in weight and handy to use.

Information Coupon

Please send detailed information about handy testers:

- for V.24/V.28 Interfaces
 for X.20/21, X.26/27 Interfaces

Name

Firm

Address

City

Tel. No.

E 2251 K

Wandel & Goltermann

(Schweiz) AG
 Postfach 254
 CH-3000 Bern 25
 Tel. (031) 42.66.44
 Telex 32 112 wago ch



Détecteur à ultrasons

Delta USD 120,

Détection rapide, précise de fuites d'air et d'inétanchéités petites et minimes:

entièrement électronique, pour conduction du son par le corps, excès de pression et vacuum.
 Avec pile rechargeable, signalisation optique et acoustique.
 Information, prospectus:

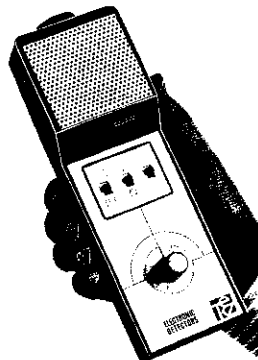

TECHNOKONTROLL AG

8049 Zürich, Imbisbühlstr.144 Telefon 01 56 56 33

RICO-Gouttières à câbles Chemins de câbles



Eléments fabriqués en série, disponibles de stock, prêts à être assemblés selon le principe de la boîte de construction, permettent des gains de temps importants dans l'établissement des plans, dans les bureaux d'études, sur le chantier et à l'atelier.

1/4

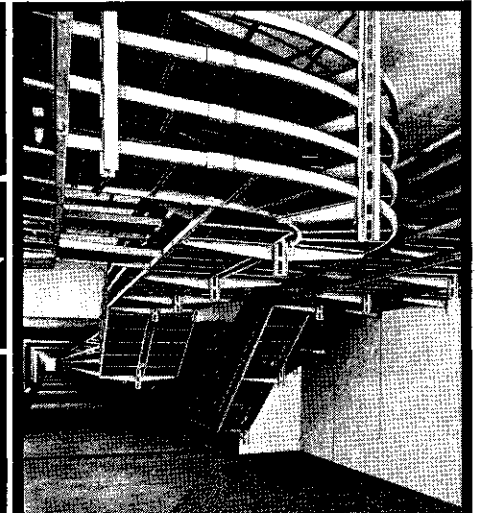
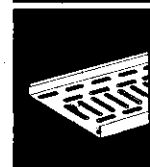
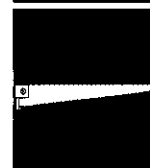
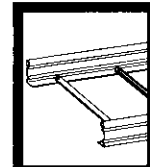

RIETH & Co. GmbH
 Fabrik für Eisenkonstruktionen
 D-7312 Kirchheim-Teck
 Telefon (0 70 21) 4 50 51
 Telex 7 267 881

Schweiz
 Bruno Winterhalter AG
 Oberwiesenstraße 4
 CH-8304 Wallisellen
 Telefon 01-8 30 10 11
 Telex 53 132

Spellman's High Power resonant inverter outperforms units 9 times its size

Power for X-Ray Systems

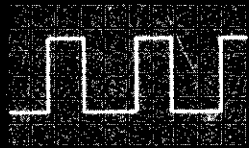

Typical $\pm 75\text{KV}$ Pulse

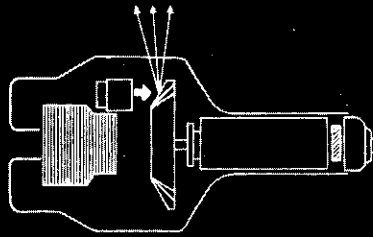

- 0 to $\pm 75\text{KV}$ in less than 5mS
- Low Capacitance Filament Supplies
- Up to 30KW

Power for Ion Implantation

- Indestructible in Vacuum Arcs
- Lowest Stored Energy
- Up to 200KV ... Up to 10KW



Power for Lasers

- Current Driven for Pulsed Lasers

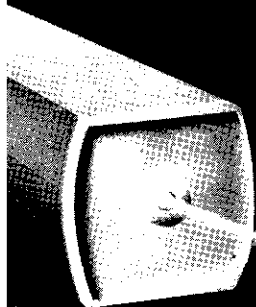

Typical Voltage Pulse Waveform



RHP 3KW Series

- Flexibility for the Laboratory
- Voltage Ranges From 3KV to 200KV
- Automatic Crossover for Current or Voltage Regulation
- Fully Programmable

The most important breakthrough in High Voltage Power Supply technology in more than 20 years

Spellman's new series resonant inverter produces pure sinusoidal current to generate high voltage power without the disadvantages inherent in conventional technologies... eliminating line frequency magnetic components... eliminating vacuum tubes... eliminating oil. This high frequency approach reduces size and weight while the sinusoidal shape of the current waveform eliminates electromagnetic interference and provides failsafe current limiting and short circuit protection. Low stored energy and 50KHz ripple frequency contribute to the unit's indestructibility under vacuum arcing.

Other Applications

- Klystron and TWT Supplies
- E-Beam Systems
- Capacitor Chargers

Features

- Extremely Compact Design
- 0.01% Voltage Regulation
- 0.02% RMS Ripple
- High Frequency Operation

Options

- Remote Voltage Programming
- Wide Range of Additional Options
- IEEE Bus Interface
- Voltage and Current Test Points

Spellman
High Voltage Electronics Corp

7 Fairchild Avenue, Plainview, New York 11803 (516) 349-8686 TWX: 510-221-2155
Engineering opportunities available. Write to personnel department.

bergoz



we build your
electronic equipment

BERGOZ - CROZET - 01170 GEX, France (50) 41 00 89
Electronic Equipment Manufacturing

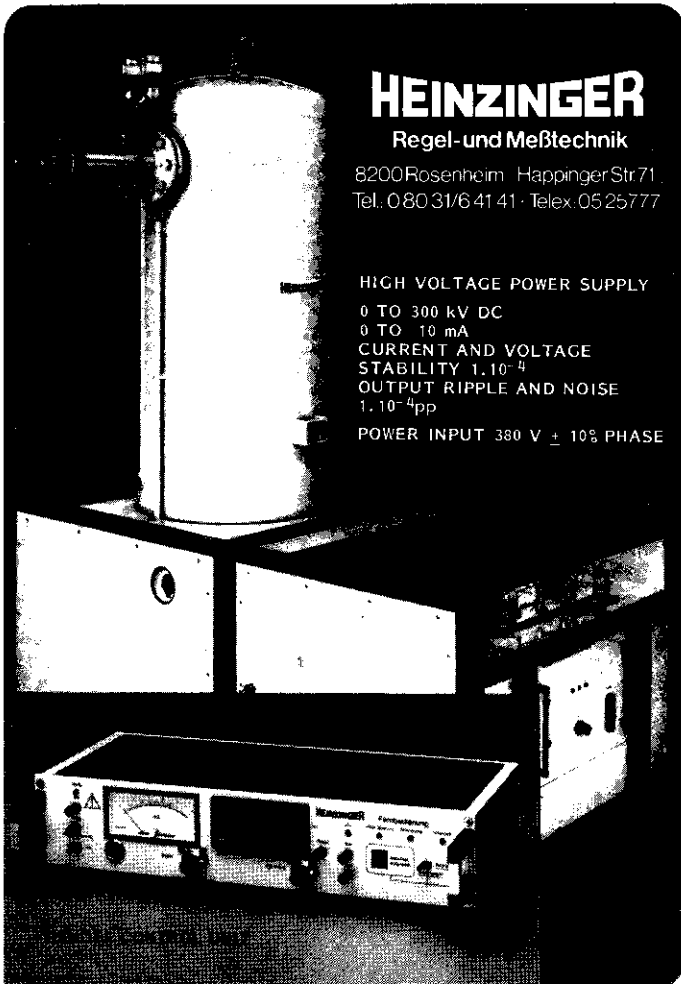

HEINZINGER

Regel- und Meßtechnik

8200 Rosenheim · Happinger Str. 71
Tel.: 080 31/6 41 41 · Telex: 05 25777

HIGH VOLTAGE POWER SUPPLY

0 TO 300 kV DC
0 TO 10 mA
CURRENT AND VOLTAGE
STABILITY $1 \cdot 10^{-4}$
OUTPUT RIPPLE AND NOISE
 $1 \cdot 10^{-4}$ pp
POWER INPUT 380 V \pm 10% PHASE

CERN COURIER

A unique advertising medium for
scientific and technical equipment

CERN COURIER is the internationally recognized news magazine of high energy physics. Distributed to all the major Laboratories of the world active in this dynamic field of fundamental research, it is compulsive reading for scientists, engineers, administrators, information media and buyers. Written in simple language and published simultaneously in English and French it has become the natural communication medium for particle physicists in Europe, the USA, the Soviet Union, Japan—everywhere where the fundamental nature of matter is studied.

Published from CERN, Switzerland, it also has correspondents in the Laboratories of Argonne, Berkeley, Brookhaven, Cornell, Fermi, Los Alamos and Stanford in the USA, Darmstadt, DESY and Karlsruhe in Germany, Orsay and Saclay in France, Frascati in Italy, Daresbury and Rutherford in the U.K., SIN in Switzerland, Dubna and Novosibirsk in the USSR, KEK in Japan, TRIUMF in Canada and Peking in China.

The annual expenditure on high energy physics in Europe is about 1000 million Swiss francs. The expenditure in the USA is about \$ 400 million. There is similar expenditure in the Soviet Union.

CERN COURIER is the way into all high energy physics research Laboratories. If you have a market in this field, there is no surer way to make your products known than by advertising in CERN COURIER.

All enquiries to:

Advertising Manager
Micheline Falciola
CERN COURIER
CERN
CH - 1211 GENEVA 23
Tel. (022) 83 41 03
Telex 236 98

LARGE CALORIMETERS?

XP2008 and XP2012 contribute in UA1 and UA2 pp̄ CERN experiments with

A complete range of modern PMTs for industry and physics

PMT	cathode		number of stages	stability		pulse linearity (mA)	resolution ¹³⁷ Cs (%)
	∅ (mm)	type		16h/0,3μA (%)	1-0,1μA (%)		
XP2008	32	super A	10	1	1	200	8
XP2012	32	bialkali	10	1	1	200	7,2
XP2202	44	bialkali	10	1	1	200	7,4
XP2212	44	bialkali	12	1	1	250	7,5
XP2030	70	bialkali	10VB	0,5	0,8	40*)	7,2
XP2050	110	bialkali	10VB	1	1	40*)	7,5

*) with a specially tailored bleeder

Matching the BBQ emission spectrum (BBQity), these PMTs

meet the most critical parameter for system resolution: GAIN STABILITY.

Philips Industries,
Electronic Components
and Materials Division,
Eindhoven, The Netherlands

We've set the standard for over 20 years



Electronic
Components
and Materials

PHILIPS

VIMMA

**REALIZES
HIGH-PRECISION
MECHANICAL
ON COMMISSION
FOR ALL
THOSE COMPANIES
WHICH OPERATE
IN THE
FOLLOWING AREAS**

HIGH-PRECISION EQUIPMENTS
AIR AND HELICOPTER SECTOR
ROCKETRY SECTOR
RADAR EQUIPMENT
TELECOMMUNICATION SYSTEM
INFORMATICS
CAR INDUSTRY
FOOD INDUSTRY MACHINERY
TEXTILE INDUSTRY

Vimma offers a long tradition in the high-precision mechanical, wide productive means with advanced technology, continual researches on materials and, above all, professionally prepared men for solving every problem.

Vimma Company is supplier of INFN (National Institute of Nuclear Physics).



HIGH-PRECISION MECHANICAL WORKSHOPS
C.so di Porta Nuova, 42/44
20121 Milano - Italy
Tel. (02) 659.25.89-664.082

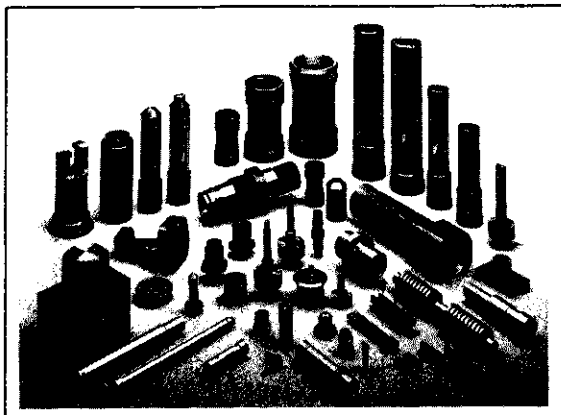

Corps de chauffe au silicone

Nous utilisons le silicone pour fabriquer des rubans chauffants souples, des tissus chauffants et des corps de chauffe profilés. Physiquement stables, ils résistent à presque toutes les influences chimiques. Ils sont très souples, étanches à l'eau et électriquement sûrs. Ils conviennent également pour tous usages jusqu'à 200°C.

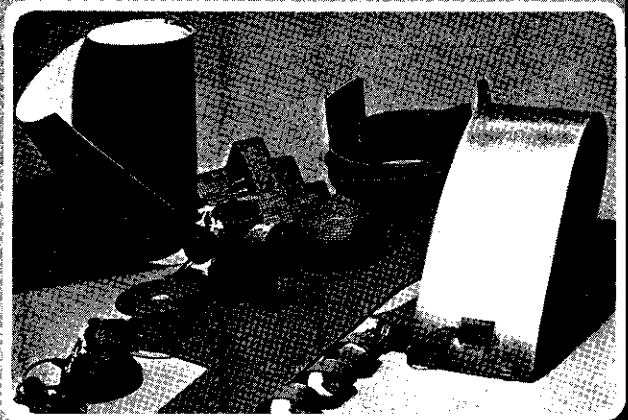

Vous trouverez des renseignements sur la gamme de nos produits et leur champ d'utilisation dans notre catalogue d'information « Chauffage industriel » HW 130/51

Tous les éléments chauffants: rubans, câbles, tissus, plaques et tuyaux souples. Chauffage de fûts, chauffe-balloirs. Dispositifs de réglage, accessoires de montage.

WISAG

**Heracetus
WITTMANN**

Darlifonerstr. 99, CH-8057 Zürich
Tel. 01/211 40 40

Composite Shielding Materials

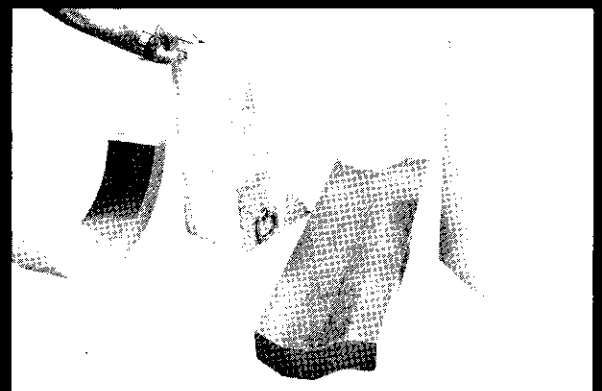

For ■ **POWER REACTORS**
■ **RESEARCH REACTORS**
■ **PARTICLE ACCELERATORS**
■ **ISOTOPE SOURCES**

BASE MATERIALS: Refractories, Polyethylenes, Silicones, Clays.

ADDITIVES: Hydrogen, Boron, Lithium, Lead, Cadmium, Rare Earths.

FORMS: Bricks, Slabs, Cylinders, Blankets, Pellets, Casks, Castables, Pipe Shields.

SEND FOR COMPLETE CATALOG



REACTOR EXPERIMENTS, INC.

963 Terminal Way, San Carlos, California 94070 USA
(415) 592-3355 • Cable: REACTEX • Telex: 345 505 (REACTEX SCLS)

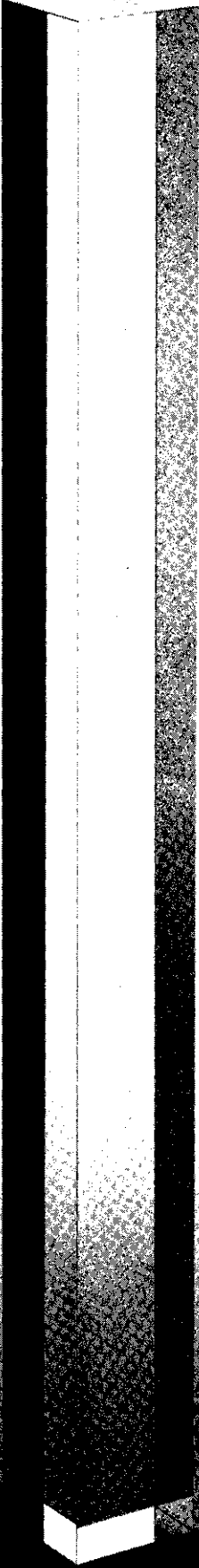

Ohara Scintillation Glass, Type SCG-1

Five times the light output of lead glass...and a reasonable cost.

Our new SCG-1 scintillation glass has a per volume cost roughly 50% higher than SF5 lead glass, but less than 10% of the cost of sodium iodide. Resistance to radiation damage is 100 times better than lead glass.

SCG-1 Characteristics:

Radiation Length (cm)	4.35
Refractive Index (nd)	1.603
Density (g/cm ³)	3.36
Linear Coefficient of Thermal Expansion (100–300°C) (10 ⁻⁷ /°C)	108
Stimulation Wavelength (nm)	375
Fluorescent Wavelength (nm)	429
Fluorescent Life Time (n. sec)	80
Light Output	5.0 times as high as SF5

SCG-1 must be protected from strong ultraviolet light, like sunlight and mercury lights.

Finely polished pieces ready for use in counters are made to your size and shape specifications including square, rectangular, hexagon, and disc shape.

Please contact us for further information and a proposal.



OHARA OPTICAL GLASS, INC.

300 North Zeeb Road, Danbury, New York 12820, U.S.A.

TELEPHONE: (518) 792-2000

LOOK OUT!

We are already known internationally for our unique range of **Metals** in the form of **Foils, Wires, Rods, Powders, Tubes and Compounds.**

NOW included are **Sputtering Targets, Single Crystals, Glassy Alloys, and Microfoils.** **ALSO** you can choose from a carefully selected range of high performance materials **Polymers, Composites, Honeycombs, Ceramics...** for your research and design work.

Goodfellow
Catalogue 7

Research Metals and High Performance Materials

Try us first!

If you need metals and materials *fast* then everything in our catalogue is in-stock for immediate despatch anywhere in the world.

Goodfellow Metals Ltd Cambridge Science Park
Milton Road Cambridge CB4 4DJ England
Tel. Cambridge (0223) 69671 Telex 81683 Goodm1 G

Goodfellow

Pour des moteurs pas à pas il faut voir le **NOUVEAU** programme Crouzet

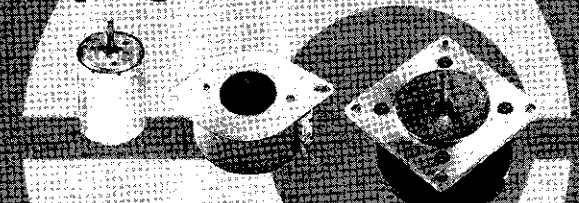

Moteurs pas à pas à aimant permanent 7,5, 15, 30, 60, 120, 240, 480, 960, 1920, 3840 pas
deux ou quatre phases, avec ou sans commande, de 21 à 275 mNm. ϕ 35,5/51/57,5/65 mm

Moteurs pas à pas hybrides 1,8° ou 3,6°
deux ou quatre phases, avec ou sans commande
de 60 à 3000 mNm.

Et aussi des nouveautés dans la gamme étendue des Moteurs synchrones et à courant continu.

Documentation complète à votre disposition
si vous recherchez performance et fiabilité à des prix compétitifs, contactez Crouzet.

Crouzet

Crouzet SA
Buckhäuserstrasse 24
8048 Zurich, Tel. 01/52 41 20

Un maillon dans le réseau mondial Crouzet.

RF TECHNOLOGY Components and Engineering



- Monopulse Comparators
- Pressurization Systems
- Microwave Absorbers
- Coax and Waveguide
- Waveguide Switches
- Open Wire Switches
- Coax Breakaways
- Coaxial Switches
- Phase Shifters
- Stub Tuners
- DC Breaks
- Combiners
- RF Loads

Contact Dielectric for all your RF needs from mW to MW.

DIELECTRIC COMMUNICATIONS

A UNIT OF GENERAL SIGNAL
Tower Hill Road • Raymond, Maine 04071
Tel.: (207) 655-4555 • 800-341-9678
TWX: 710-229-6890

PETROLEUM TECHNICAL COMPANY S.A.

PTEE TEFLON

Pumps and accessories for handling corrosive alimentary, sterile fluids.

Pneumatic operated self priming pumps for gases and liquids. 10 to 4000 l/h.

We can offer for use with our circulating and dispensing pumps a wide range of tubing, connector pieces and valves constructed in P.T.F.E which enable them to be mounted to suit most applications for both corrosive liquids and gases.

PETROLEUM TECHNICAL COMPANY S.A.
47, chemin des Mésanges
CH 1225 Chêne-Bourg (Geneva) Switzerland
Phone (022) 48 67 49 Telex 23897 PTC CH

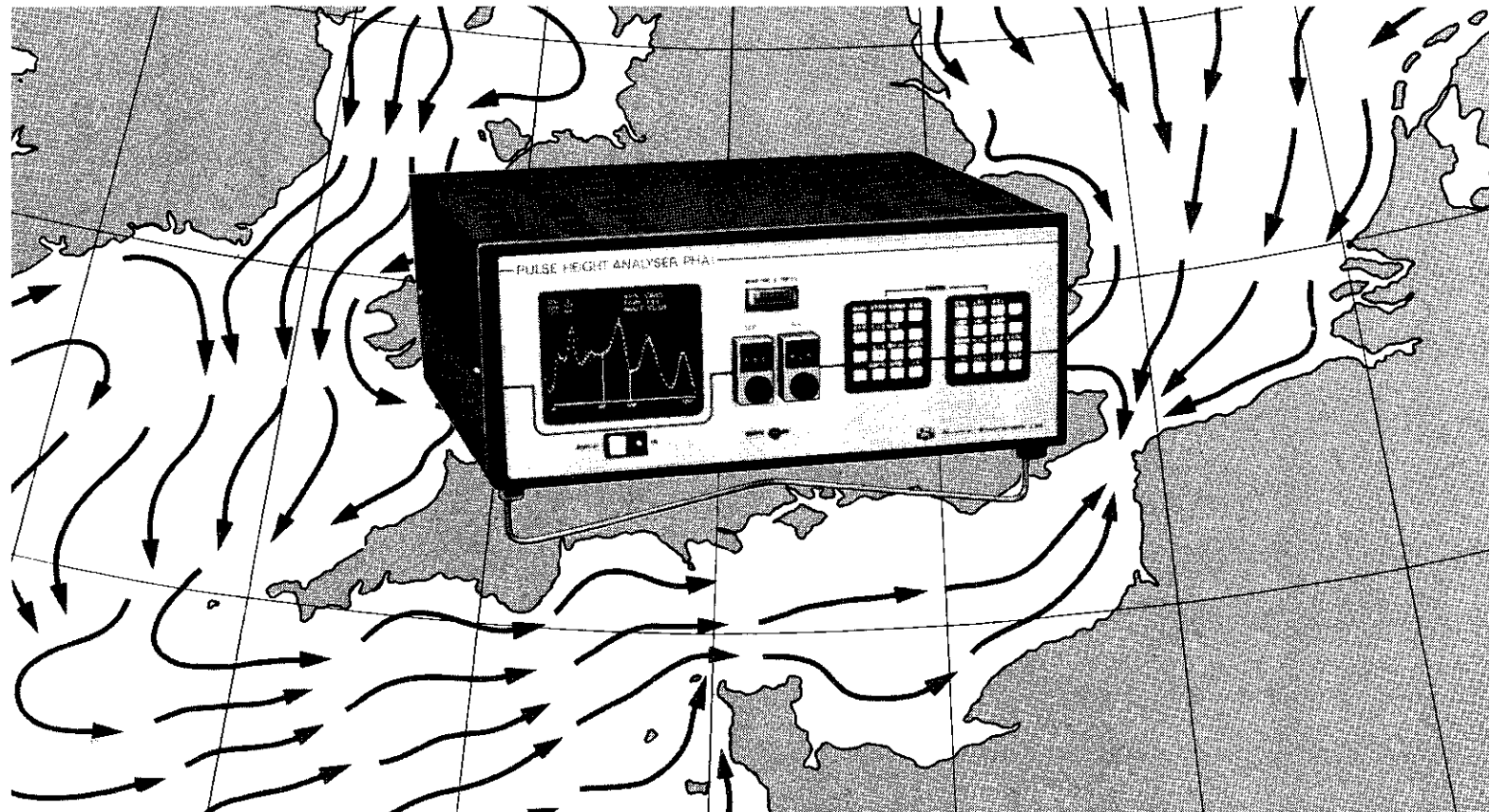

The PHA1 Channel Analyser

The PHA1 1K analyser has been specially designed and manufactured by Europe's leading nucleonic specialists — Nuclear Enterprises Limited and Numelec S.A.

Designed for general spectroscopy work, its built-in raster scanned display is exceptionally stable and can drive external large screen monitors.

Scintillation detectors can be directly connected because preamplifier, amplifier and high voltage supply are built-in. An ADC with adjustable conversion gain completes the pulse processing system, and offers excellent linearity backed by auto-incrementing memory.

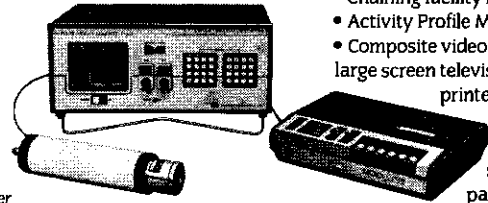

PHA1 with Scintillation Detector and Digital Recorder

ROI integration, group addition/subtraction and other simple data manipulations, plus stand-alone data logging can all be accomplished.

If you want hard copies of data, we can supply all the peripheral equipment you need. Indeed, the PHA1 can also be connected to a host processor.

For adaptability and easy servicing, the PHA1 is packaged in a Eurocard format.

Compare the specification:

- Incorporates H.V. supply, preamplifier and amplifier for direct connection of scintillation detectors
- Chaining facility for multiple operations
- Activity Profile Mode for Activity/time studies
- Composite video output for driving remote large screen television monitors and video printers
- Simplified operation using keypad entry
- Clear visual indication of spectral data and operating parameters

- Modular hardware system
- Serial interface for spectral data output and input
- Real time, live time and count limit controlled acquisition
- Integration over selected region of interest
- Dead time indication
- Good differential and integral linearity
- 256, 512, 1024 channel groups
- Data manipulation between groups
- Peripheral range includes video printer, serial printer, digital cassette recorder and host microprinter for spectral data analysis
- Small and compact

cc 1083

For comprehensive details, use the coupon and we'll send you a Free copy of our PHA1 brochure.

Name _____

Company _____

Address _____

Nuclear Enterprises Limited
 Bath Road, Beenham, Berkshire, England RG7 5PR
 Telephone: Woolhampton (073 521) 2121 Telex: 848475
 Sighthill, Edinburgh, Scotland EH11 4BY Telephone: 031-443 4060 Telex: 72333



Nuclear Enterprises
 A THORN EMI company

①

②

Degrader for High Voltage

Concerned in the case of this component is a voltage divider for the pilot experiment of «LEP-DELPHI» resp. BARREL RICH.

- ① Entire component from outside with visible electrode no. 30.
- ② Enlarged section through the electrode parts.

In a series of preliminary development stages it has been successful, to break down a defined voltage of 210 KV over 30 graded built-in electrodes.

Isolating distance between the electrodes is 0.7 mm.

The entire component was produced by the high-vacuum process.

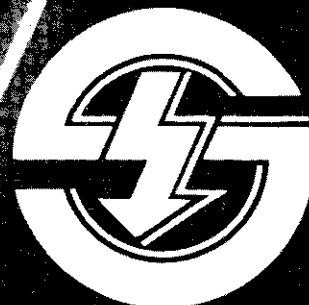

Stesalit AG
Kunststoffwerk

CH-4249 Zullwil/SO
Telefon 061/80 06 01, Telex 63182

You are looking at a CAMAC test system

which combines the following criteria :

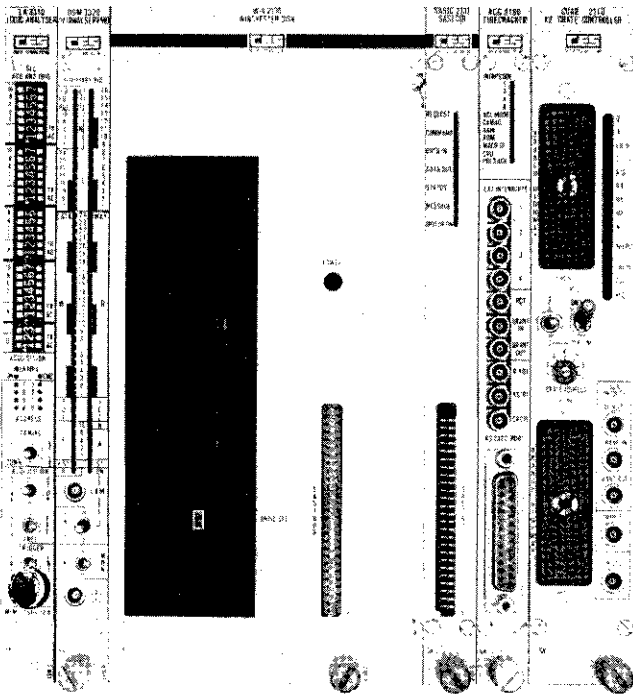

- low-cost
- reliable
- available off the shelf
- capable of the state of the art performance
- easy to operate
- transformable into a front-end system at the flick of a switch

Hardware:

CCA2 2110/DCC 2114 true A2 or dummy A2 crate controller.
 ACC 2160/2164/2165 24 Mhz 99105 processor with up to 64 Kbytes
 45ns dual-port RAM, memory extensions,...

Options:

99110 CPU CPU with floating point instruction set.
 WCTR 2131 SASI winchester/floppy controller.
 WIN 2130 Winchester disk sub-system including
 drive, interface and independant power supply.
 LA 3310/ADSM 3320 logic analyser.

Software:

The following languages are available :

Assembler, BASIC, FORTH, NODAL, PASCAL, MODULA 2.
 Assembler, BASIC, FORTH and NODAL can be EPROM based
 and do not require the WIN 2130.

You are looking at a J-11 based ACC

ACC 2180

which includes the following specifications :

- latest DEC J-11 chip with PDP 11/70 performance
- latest DEC DLART DC 319 console interface
- fast 128 Kbytes dual-port memory with mixed static RAM/EPROM.
- optional Q-Bus interface
- built-in programmable LAM grader
- additional fast three-port memories

The ACC 2180 outperforms current top-of-range micros and runs standard DEC software.

If you want to have a look at the real thing,
 one unit will be circulated amongst our agents
 for the next three months, so contact them at once.



At CES, tomorrow's systems are available NOW

For more information contact us, or your local CES representative:

70, route du Pont-Butin Case Postale 122 1213 Petit-Lancy 1 Switzerland
 Tel: (022) 92 57 45 Telex: 421320 CES-CH



Belgium:	Canberra Positronika	Tel: (54) 321611	Netherlands:	Canberra Positronika	Tel: (040) 416355
North America:	Bytech Eng. Vancouver	Tel: (604) 7387784	Japan:	Toyo Corp.	Tel: (03) 2790771
France:	AB+B	Tel: (76) 905540	North Germany:	PCP	Tel: (040) 802046
South Germany:	Silena	Tel: (060) 554021	England:	Nuclear Enterprises	Tel: (073) 5212121

PHOTOMULTIPLIER BASES

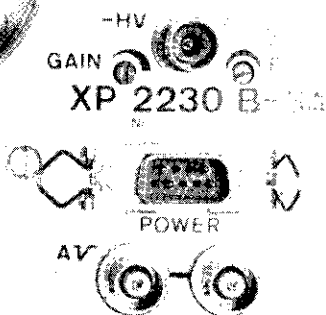
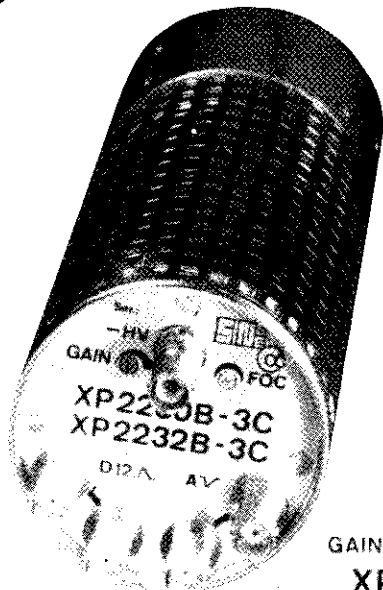

FOR FAST COUNTING APPLICATIONS

- XP 2230B-3C** For counting scintillators or long decay time at counting rates up to 70MHz. This PM is also designed for XP 2262B as well. Gain adjustable 1 : 100.
- XP 2232B-3C** For counting scintillators or long decay time at counting rates up to 70MHz. This PM is also designed for XP 2262B as well. Gain adjustable 1 : 100.
- XP 2020-3C** For scintillators with long decay time and plastic scintillators at counting rates up to 100MHz. Gain adjustable 1 : 100.
- XP 2020-3A** For plastic scintillators at high counting rates up to 125MHz. Gain adjustable 1:100. Build-in x10 Amplifier and Filter.
- XP 2230B-3A** For ultra-high speed applications up to 150MHz. Build-in x10 Amplifier and 100 Ohm Filter for best timing resolution.



ORBIT CONTROLS AG

Zürcherstrasse 20
CH-8952 SCHLIEREN

Tel.: (01) 730-2753
Tx.: 59834 orbit ch

Licence

Economisez! Filtrez avec le filtre Luwa à poussière fine type FP. Ses 17 m² de surface filtrante garantissent une plus longue durée de vie.

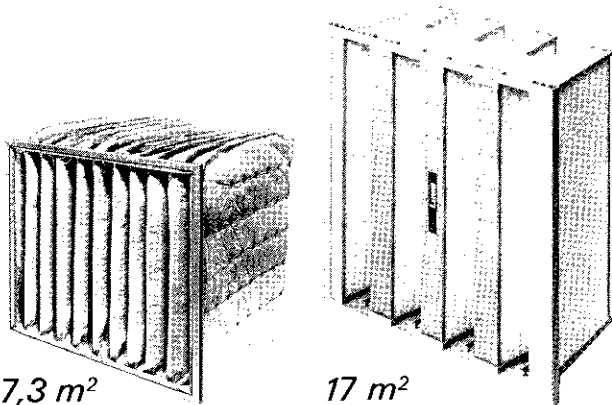

Succursales, licenciés et représentations dans plus de 60 pays.

Luwa

Luwa SA
Filtres + Equipement de Protection
Kanalstrasse 5, 8152 Glattbrugg, Téléphone 01/810 10 10

If you need

Check valves

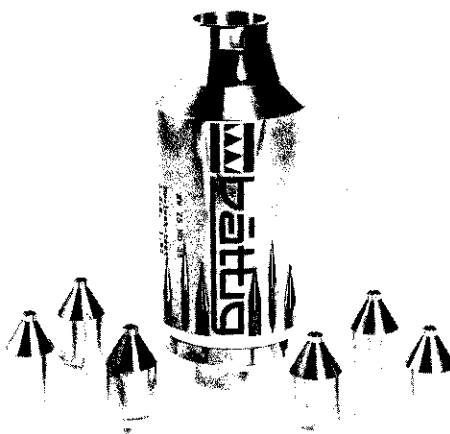

Please contact:



Alfred Bättig AG
CH-8400 Winterthur/Switzerland
Phone: 052/25 27 69 Telex: 76617 valve ch

TOP PERFORMERS NEED ENERGY AND TECHNIQUE.

INTERATOM-employee
Brigitte Kraus,
German champion
and vice world champion
in the 3000 meters.

Top performers get where they are through systematic work. Both in sport and in industry. Energy and know-how are the key to success. And INTERATOM has made that its maxim for 25 years.

INTERATOM offers:

- Energy Systems Engineering
- Application of Advanced Technologies
- Research and Development
- Special Fabrication

INTERATOM
Friedrich-Ebert-Straße
D-5060 Bergisch Gladbach 1
Telephone 022 04/48 44 44
Telex 8 878 457 iagl (d)

INTERATOM

Our company brochure, which we will be pleased to supply on request, contains detailed information about INTERATOM services.

On-line Semi Custom Logic

the broadest range ...the best support

Choose choice.

Choose your technology ... TTL, CMOS, ISL or ECL ... we've got them all.

Choose your concept ... we cover the board ... everything from do-it-yourself integrated fuse logic through to sophisticated 3000-gate compact cell arrays.

Choose objective advice ... we don't need to favour any particular technology or concept.

Choose your support level ...

we've got the biggest CAD network of its kind in the world, with off- and on-line interfaces adapted to individual needs.

Support is also tailored:

1) you can deliver logic diagrams to your local Philips design center and we'll take care of the rest

2) you can work in the center, with or without engineering help

3) you can work with one of our terminals in your own office

4) you can run Philips CAD software on your own computer.

These unmatched facilities put the whole world of semi-custom logic at your finger tips

For a comprehensive brochure, giving full details of the range and the support please write to: Philips Electronic Components and Materials Division, 5600 MD Eindhoven, The Netherlands

CMOS

Gate arrays in CMOS

ACE

Gate arrays in Advanced Custom Emitter Coupled Logic

FIL

Field programmable Integrated Fuse Logic

CCL

Cell library in TTL Composite Cell Logic

ISL

Gate arrays in Integrated Schottky Logic

CCCL

Cell library in CMOS Compact Cell Logic



Electronic components and materials

PHILIPS